



Dear Sir/Madam,

Thank you for choosing Agrimate product. You are the proud owner of high technology and durable machine. Trust that our franchisee/dealer installed the product and explained you about the usage and service instructions. Please visit our authorised dealer for you future requirement of our other equipments, genuine spares, accessories and service. Service coupons are attached with this manual and you can avail free service.

About Ratnagiri

We import and market of high quality of agriculture wide range of equipment's Which we are selling through our authorized franchisee or dealer network. We are in this field from past 20 years serving the former community. For further details, you may please visit our website

www.agrimart.in

SUMMARY

152PE GENERAL GASOLINE ENGINE with single -cylinder, 4-stroke, OHV air-forced cooling is very useful and popular.

SAFFETY PRECATIONS

WARNING: The machine may be mangled or cause accident if not following the under-mentioned item:

- a. Strictly prohibit run the machine under neither overcharge, over rev nor low-charge, low-rev.
- b. Keep the oil plants filtrated adequately before usage and make sure use gasoline and oil of stated trademark.
- c. Check the degree of tightness of the bolt termly.
- d. Clean the element of air-cleaner termly and replace it if necessary.
- e. To ensure the gasoline engine cool down cool down normally, please clean up the sundries and feculence on the fan duly.
- f. Persis to current maintenance, and obviate malfunctions in time.
- g. Do not touch the muffler, flywheel etc, during in use in case of damage of clay.

b. Important bolt screw-moment:

Unit	: N.M
Connecting bolt between the cylinder and the cover (M6)	: 16N.M
Connecting bolt of the crankcase cover (M6)	: 16 N.M
Connecting rod bolt	: 12 N.M
Flywheel bolt	: 45 N.M
Other Bolts	: 8-10 N.M

OIL PLANTS SPECIFICATIONS

- a. Gasoline : recommend to use 93#gasoilne.
- b. Oil, crankcase: SE15-40 4- Stroke lubricating oil

OPERATION

1. Preparation before operation
 - a. Check the connection of each part, ensure they are in order.
 - b. Open the crankcase cover, then inject the gasoline.
 - c. Pull the handle-recoil, see if the pressure in the cylinder is natural.

2. Starting
 - a. Open the fuel tank switch and the ignition switch, then close the choke of the carburettor and turn the activator to ½-level.
 - b. Slowly pull the handle-rope for several times, inject gasoline into cylinder, and then quickly pull the rope again.
 - c. When the machine is running. Open the choke.

3. Stop running.
 - a. Turn down the accelerator, run the machine for 4-5 minutes at low rev.
 - b. Cut down the ignition switch, stop running.
 - c. Cut off the oil switch.

QUALITY GUARANTEE

Any of the malfunction or inefficiency being caused by our manufacturing (testified by our company), would enjoy our quality guarantee service within the period of validity except:

- a. Any badness or deformity or worsening of the product(s) due to improper transportation or preservation or exceeding storing time.
- b. The damage(s) of the product(s) due to not following the instructions of Owner's Manual to operate/- maintain/preserve the product(s).
- c. The product(s) is are without sales invoice or quality guaranteed card, or the serial number(s) of the product(s) is are not conform to the serial number(s) written in quality guarantee card.
- d. The damage (s) due to the force event.

ENGINE DIAGRAM & PART LIST

CONTROL

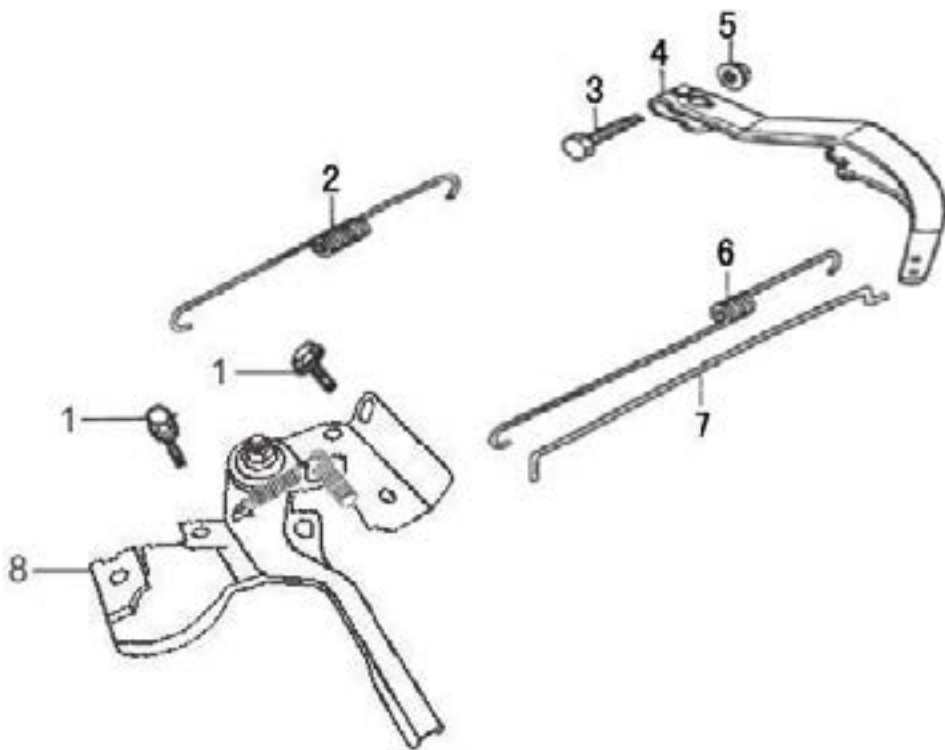

SL NO	PART NO	DESCRIPTION
1	AM-168FE-A01	Bolt Flange
2	AM-168FE-A02	Governor Spring
3	AM-168FE-A03	Bolt Flange
4	AM-168FE-A04	Arm Governor
5	AM-168FE-A05	Nut Flange
6	AM-168FE-A06	Throttle Return Spring
7	AM-168FE-A07	Governor Rod
8	AM-168FE-A08	Control. Assy

ENGINE DIAGRAM & PART LIST

FLY WHEEL- B

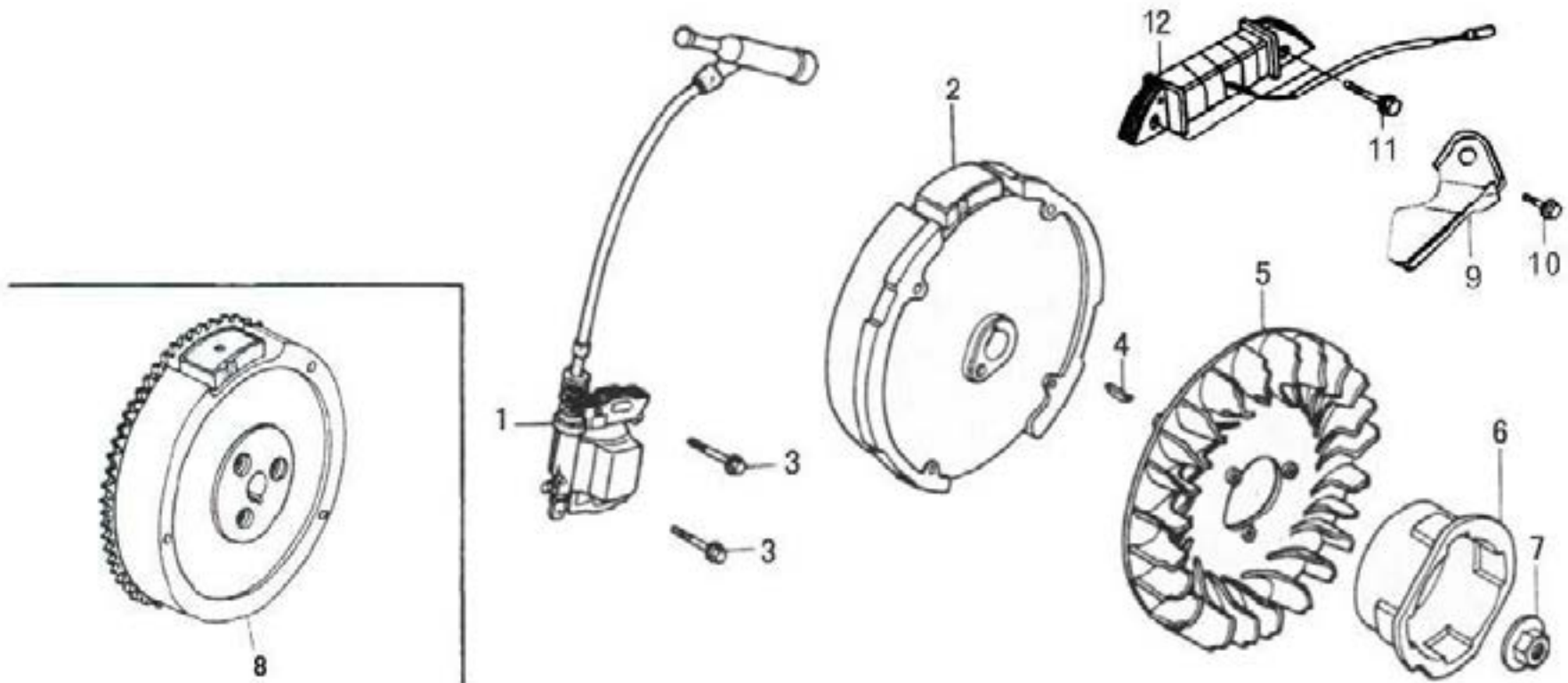

ENGINE DIAGRAM & PART LIST

SL NO	PART NO	DESCRIPTION
1	AM-168FE-B01	Ignition Coil Assy
2	AM-168FE-B02	Flywheel Comp
3	AM-168FE-B03	Flange Bolt
4	AM-168FE-B04	Key Special Woodruff
5	AM-168FE-B05	Fan Cooling
6	AM-168FE-B06	Starter Pulley
7	AM-168FE-B07	Special Nut
8	AM-168FE-B08	Flywheel Comp
9	AM-168FE-B09	Clamper Cord
10	AM-168FE-B10	Flange Bolt
11	AM-168FE-B11	Flange Bolt
12	AM-168FE-B12	Charge Coil Assy

ENGINE DIAGRAM & PART LIST

FAN COVER - C

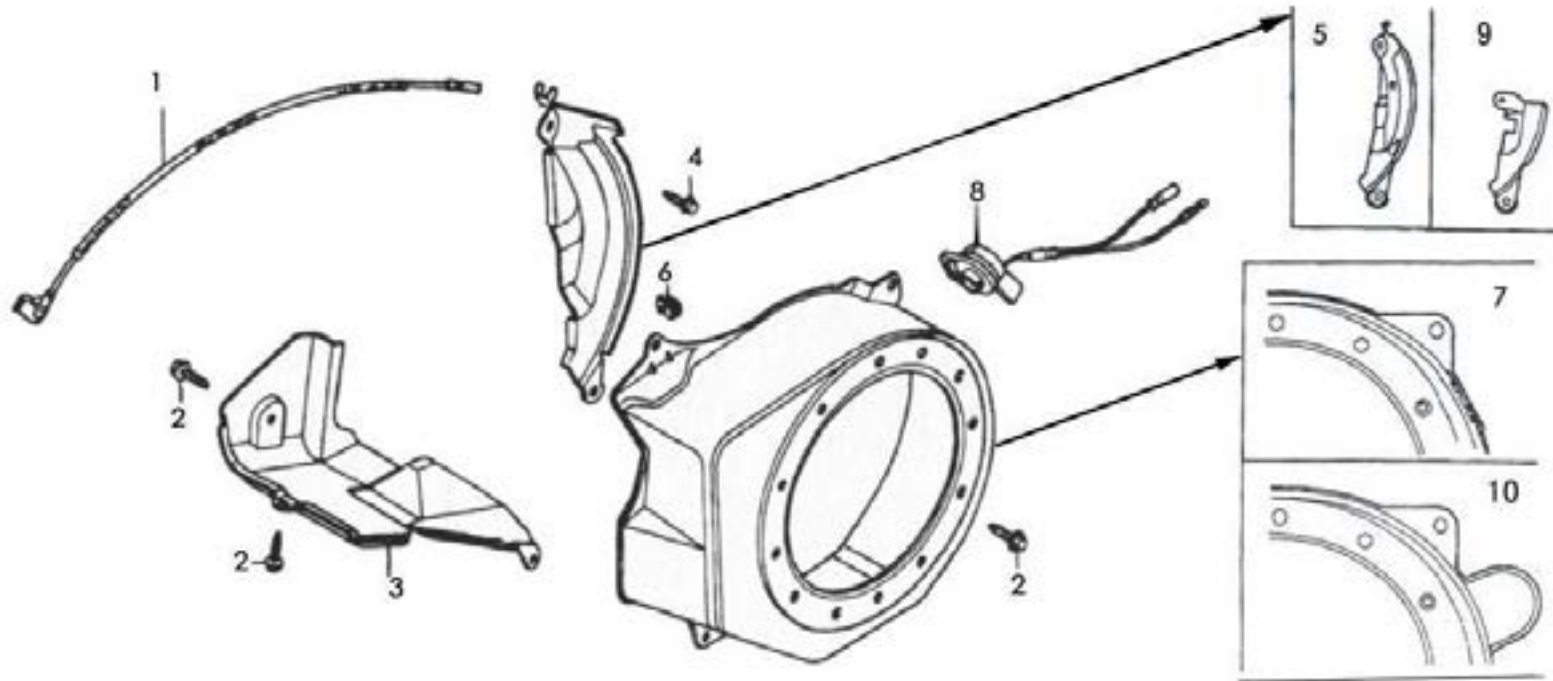

SL NO	PART NO	DESCRIPTION
1	AM-168FE-C01	Cord Stop Switch
2	AM-168FE-C02	Flange Bolt
3	AM-168FE-C03	Fairing
4	AM-168FE-C04	Flange Bolt
5	AM-168FE-C05	Lower Fairing
6	AM-168FE-C06	Clamper Cord
7	AM-168FE-C07	Fan Cover Comp
8	AM-168FE-C08	Engine Stop Switch Assy
9	AM-168FE-C09	Lower Fairing
10	AM-168FE-C10	Fairing

ENGINE DIAGRAM & PART LIST

CABURATOR-D

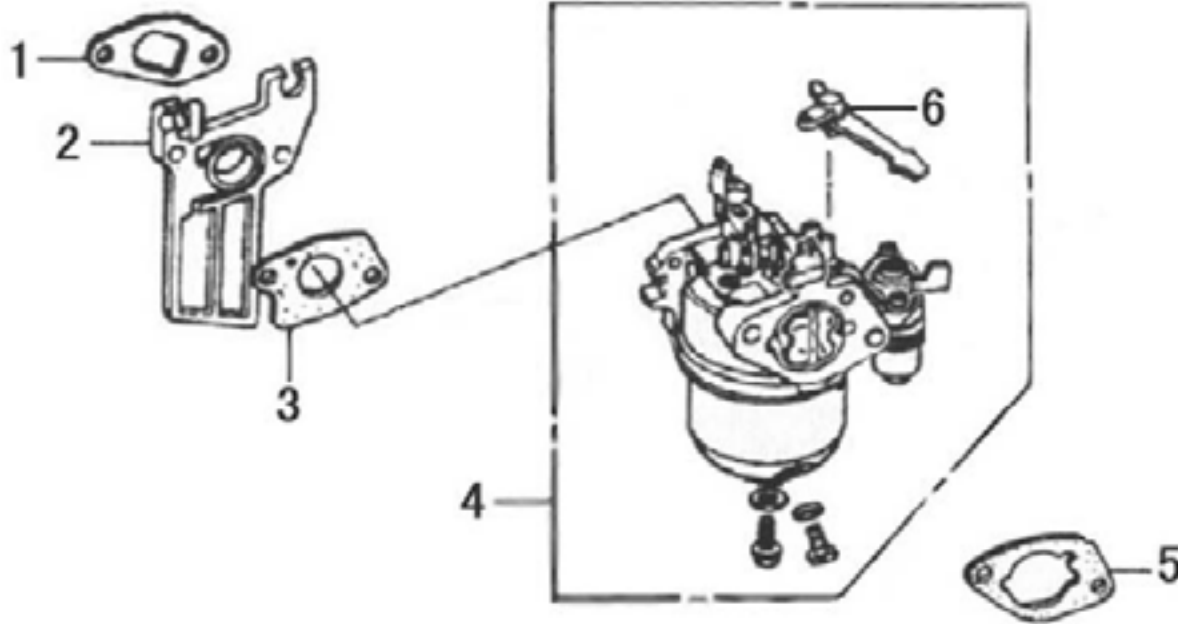

SL NO	PART NO	DESCRIPTION
1	AM-168FE-D01	Packing Carburator
2	AM-168FE-D02	Packing Insulator
3	AM-168FE-D03	Packing Carburator
4	AM-168FE-D04	Carburator Assy.
5	AM-168FE-D05	Packing, Air Cleaner
6	AM-168FE-D06	Choke Lever Comp.

ENGINE DIAGRAM & PART LIST

AIR CLEANER-E

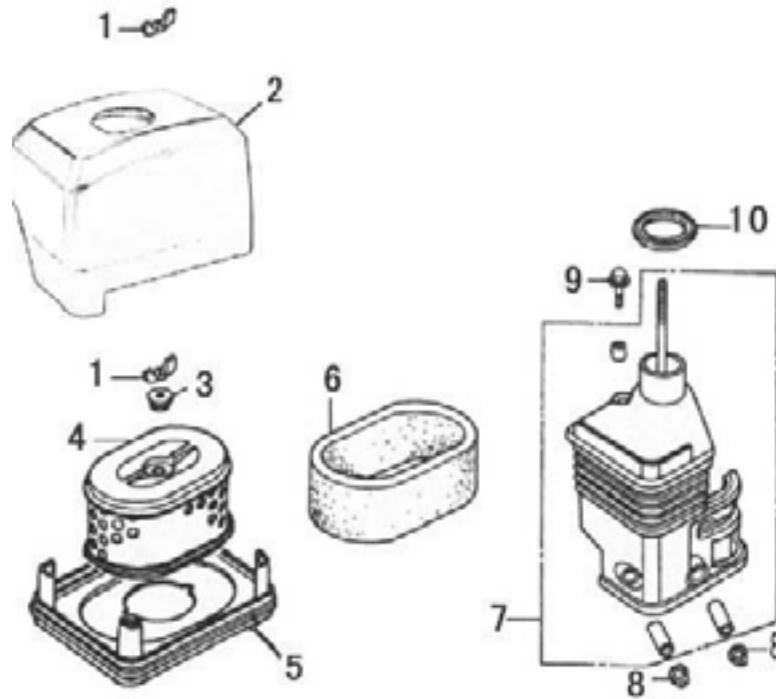

SL NO	PART NO	DESCRIPTION
1	AM-168FE-E01	Nut Tool Box Setting
2	AM-168FE-E02	Air Cleaner Cover
3	AM-168FE-E03	Air Cleaner Grommet Seal
4	AM-168FE-E04	Air Cleaner Principal Part
5	AM-168FE-E05	Aircleaner Seal
6	AM-168FE-E06	Outer Filter
7	AM-168FE-E07	Air Cleaner Elbow Comp
8	AM-168FE-E08	Flange Nut
9	AM-168FE-E09	Flange Bolt
10	AM-168FE-E10	Packing Elbow

ENGINE DIAGRAM & PART LIST

STARTER MOTOR SYSTEM ASSY-F

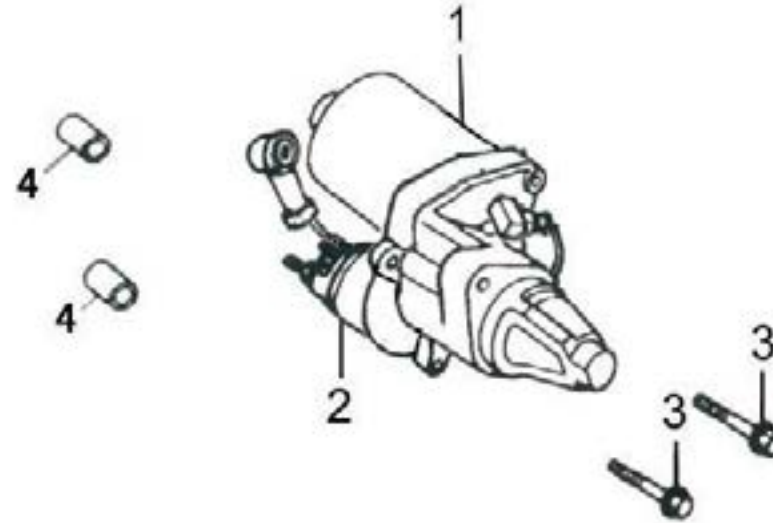

SL NO	PART NO	DESCRIPTION
1	AM-168FE-F01	Motor Starter
2	AM-168FE-F02	Contact Assy
3	AM-168FE-F03	Bolt Assy
4	AM-168FE-F04	Pin

ENGINE DIAGRAM & PART LIST

STARTER SUBASSEMBLY-G

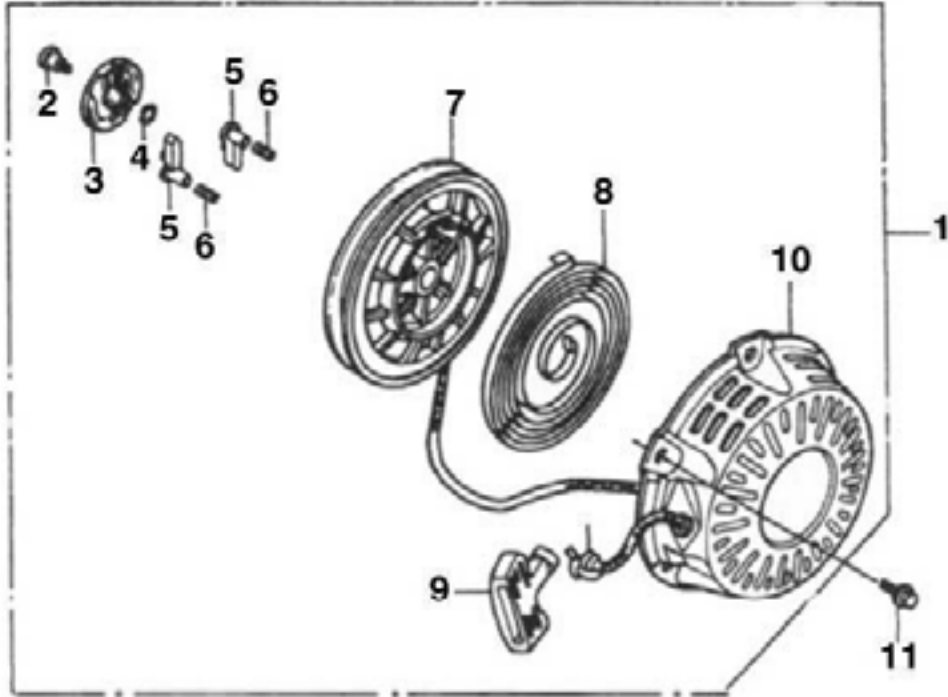

SL NO	PART NO	DESCRIPTION
1	AM-168FE-G01	Starter Assy
2	AM-168FE-G02	Screw Setting
3	AM-168FE-G03	Ratchet Guide
4	AM-168FE-G04	Spring Friction
5	AM-168FE-G05	Ratchet Starter
6	AM-168FE-G06	Spring Return
7	AM-168FE-G07	Recoil Starter Reel
8	AM-168FE-G08	Recoil Starter Spring
9	AM-168FE-G09	Recoil Starter Knob
10	AM-168FE-G10	Recoil Starter Case Comp
11	AM-168FE-G11	Flange Bolt

ENGINE DIAGRAM & PART LIST

CYLINDER HEAD-H

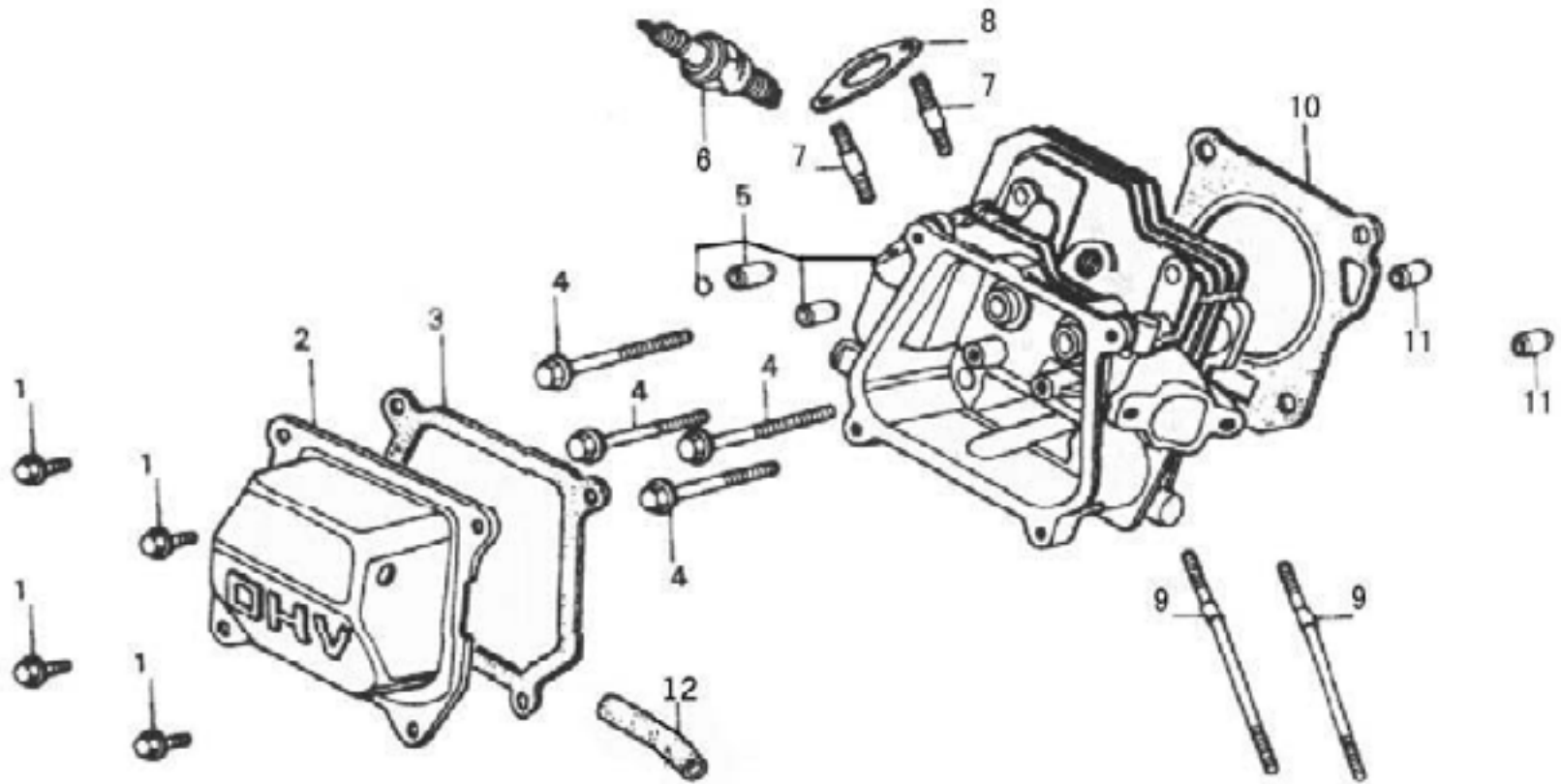

SL NO	PART NO	DESCRIPTION	SL NO	PART NO	DESCRIPTION
1	AM-168FE-H01	Flange Bolt	7	AM-168FE-H07	Exhaust Stud Bolt
2	AM-168FE-H02	Head Cover Comp	8	AM-168FE-H08	Muffler Gasket
3	AM-168FE-H03	Packing Head Cover	9	AM-168FE-H09	Intake Stud Bolt
4	AM-168FE-H04	Flange Bolt	10	AM-168FE-H10	Cylinderhead Gasket
5	AM-168FE-H05	Cylinder Head Comp	11	AM-168FE-H11	Pin Dowel
6	AM-168FE-H06	Plug Spark	12	AM-168FE-H12	Waste Pipe

ENGINE DIAGRAM & PART LIST

CRANKSHAFT PISTON-J

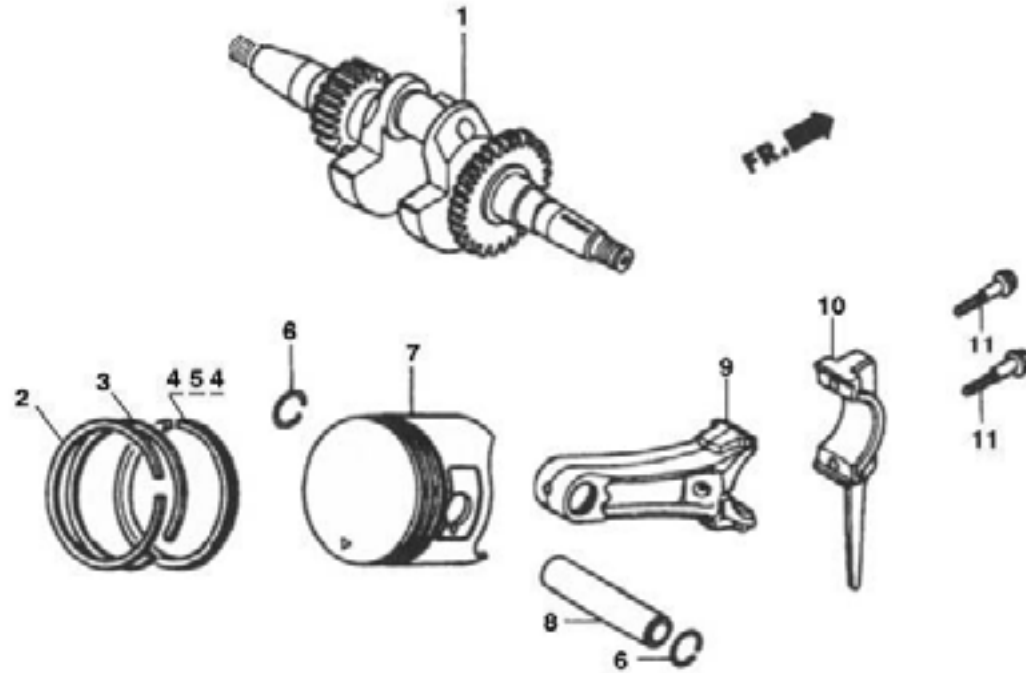

SL NO	PART NO	DESCRIPTION	SL NO	PART NO	DESCRIPTION
1	AM-168FE-J01	Crankshaft Comp	7	AM-168FE-J07	Piston
2	AM-168FE-J02	Ring Set Piston A	8	AM-168FE-J08	Pin Piston
3	AM-168FE-J03	Ring Set Piston B	9	AM-168FE-J09	Connecting Rod
4	AM-168FE-J04	Oil Ring Piston A	10	AM-168FE-J10	Connecting Cover
5	AM-168FE-J05	Oil Ring Piston B	11	AM-168FE-J11	Bolt Connecting Rod
6	AM-168FE-J06	Piston Pin Clip			

ENGINE DIAGRAM & PART LIST

CRANK CASE COVER-K

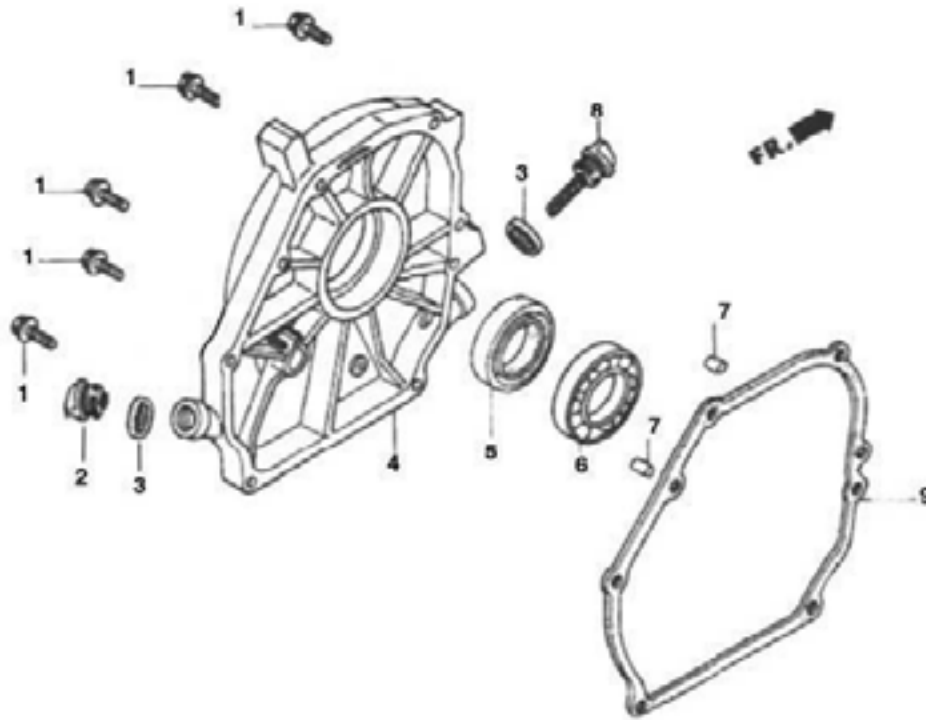

SL NO	PART NO	DESCRIPTION
1	AM-168FE-K01	Flange Bolt
2	AM-168FE-K02	Oil Stick
3	AM-168FE-K03	Packing, Oil Filler Cap
4	AM-168FE-K04	Crank Case Cover
5	AM-168FE-K05	Oil Seal
6	AM-168FE-K06	Bearing, Radial Ball
7	AM-168FE-K07	Pin Dowel
8	AM-168FE-K08	Oil Stick
9	AM-168FE-K09	Packing Crank Case Cover

ENGINE DIAGRAM & PART LIST

CAMSHAFT -L

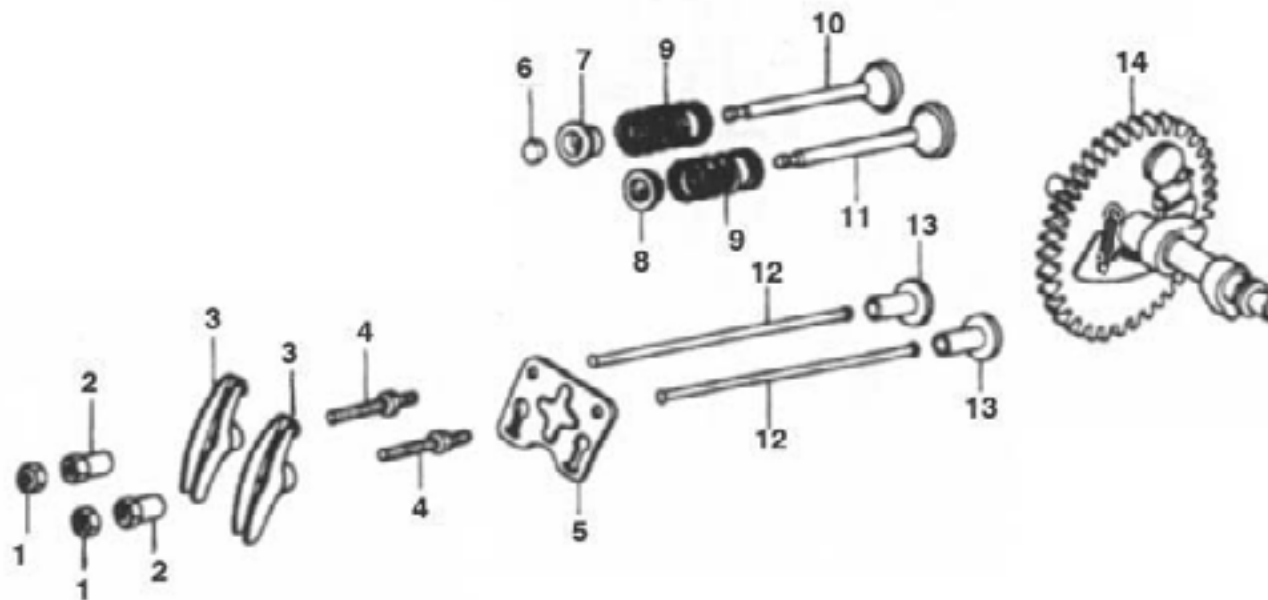

SL NO	PART NO	DESCRIPTION	SL NO	PART NO	DESCRIPTION
1	AM-168FE-L01	Valve Locking Nut	8	AM-168FE-L08	Retainer, In Valve Spring
2	AM-168FE-L02	Valve Adjusting Nut	9	AM-168FE-L09	Spring, Valve
3	AM-168FE-L03	Valve Rocker Arm	10	AM-168FE-L10	Valve Ex.
4	AM-168FE-L04	Valve Adjusting Bolt	11	AM-168FE-L11	Valve In
5	AM-168FE-L05	Push Rod Guide Plate	12	AM-168FE-L12	Rod Push
6	AM-168FE-L06	Valve Adjusting Cap	13	AM-168FE-L13	Lifter
7	AM-168FE-L07	Retainer, Ex Valve Spring	14	AM-168FE-L14	Camshaft Assy

ENGINE DIAGRAM & PART LIST

CYLINDER BARREL-M

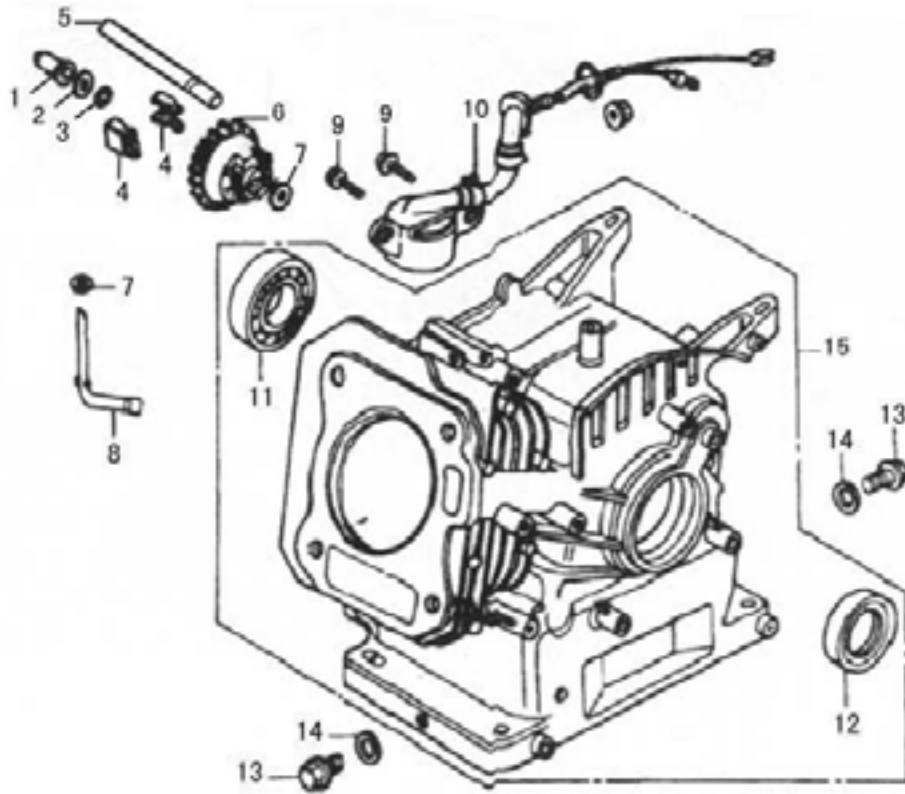

SL NO	PART NO	DESCRIPTION
1	AM-168FE-M01	Governor Slider
2	AM-168FE-M02	Washer Thrust
3	AM-168FE-M03	Governor Holder Clip
4	AM-168FE-M04	Weight Governor
5	AM-168FE-M05	Shaft Governor Centre
6	AM-168FE-M06	Nylon Gear Governor
7	AM-168FE-M07	Washer Holder
8	AM-168FE-M08	Shaft Governor Arm
9	AM-168FE-M09	Bolt Flange
10	AM-168FE-M10	Oil Sensor
11	AM-168FE-M11	Bearing Radial Ball
12	AM-168FE-M12	Oil Seal
13	AM-168FE-M13	Drain Plug Bolt
14	AM-168FE-M14	Washer Drain Plug
15	AM-168FE-M15	Camshaft Assy

ENGINE DIAGRAM & PART LIST

MUFFLER -N

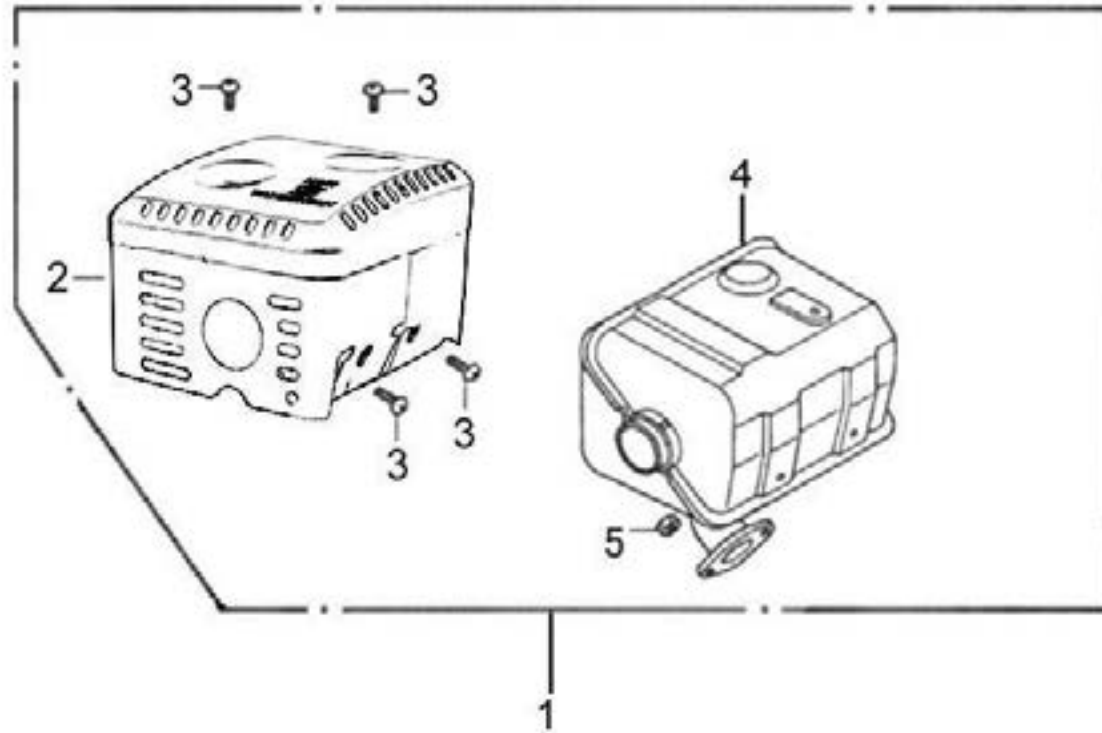

SL NO	PART NO	DESCRIPTION
1	AM-168FE-N01	Muffler Assy
2	AM-168FE-N02	Protector Muffler
3	AM-168FE-N03	Tapping Screw
4	AM-168FE-N04	Muffler Comp
5	AM-168FE-N05	Nut Exhaust Pipe

ENGINE DIAGRAM & PART LIST

FUEL TANK-P

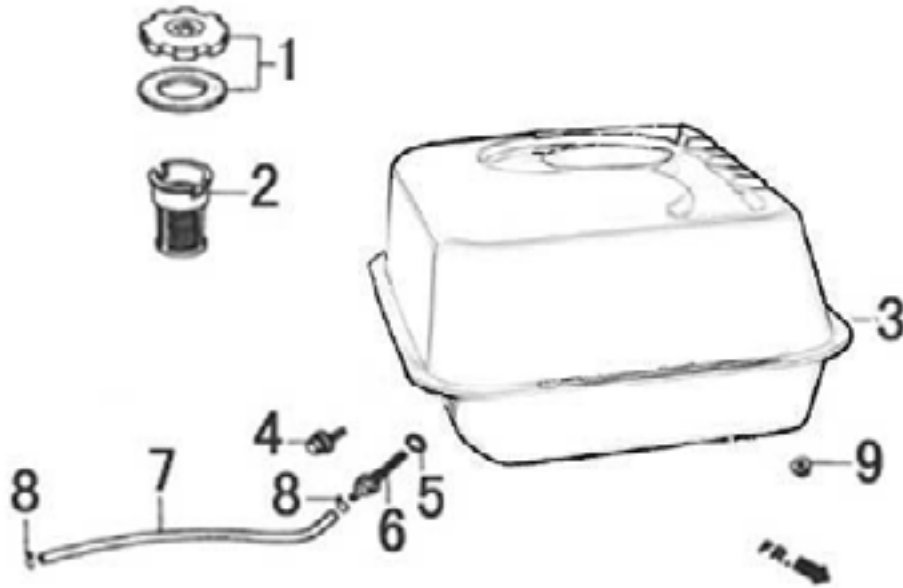

SL NO	PART NO	DESCRIPTION
1	AM-168FE-P01	Fuel Filler Cap Comp
2	AM-168FE-P02	Fuel Filter
3	AM-168FE-P03	Fuel Tank Comp
4	AM-168FE-P04	Flange Bolt
5	AM-168FE-P05	O-Ring
6	AM-168FE-P06	Joint Fuel Tank
7	AM-168FE-P07	Fuel Tube
8	AM-168FE-P08	Clip Tube
9	AM-168FE-P09	Nut Flange

PUMP DIAGRAM OF AM-30K & AM-22K HTP POWER SPRAYER

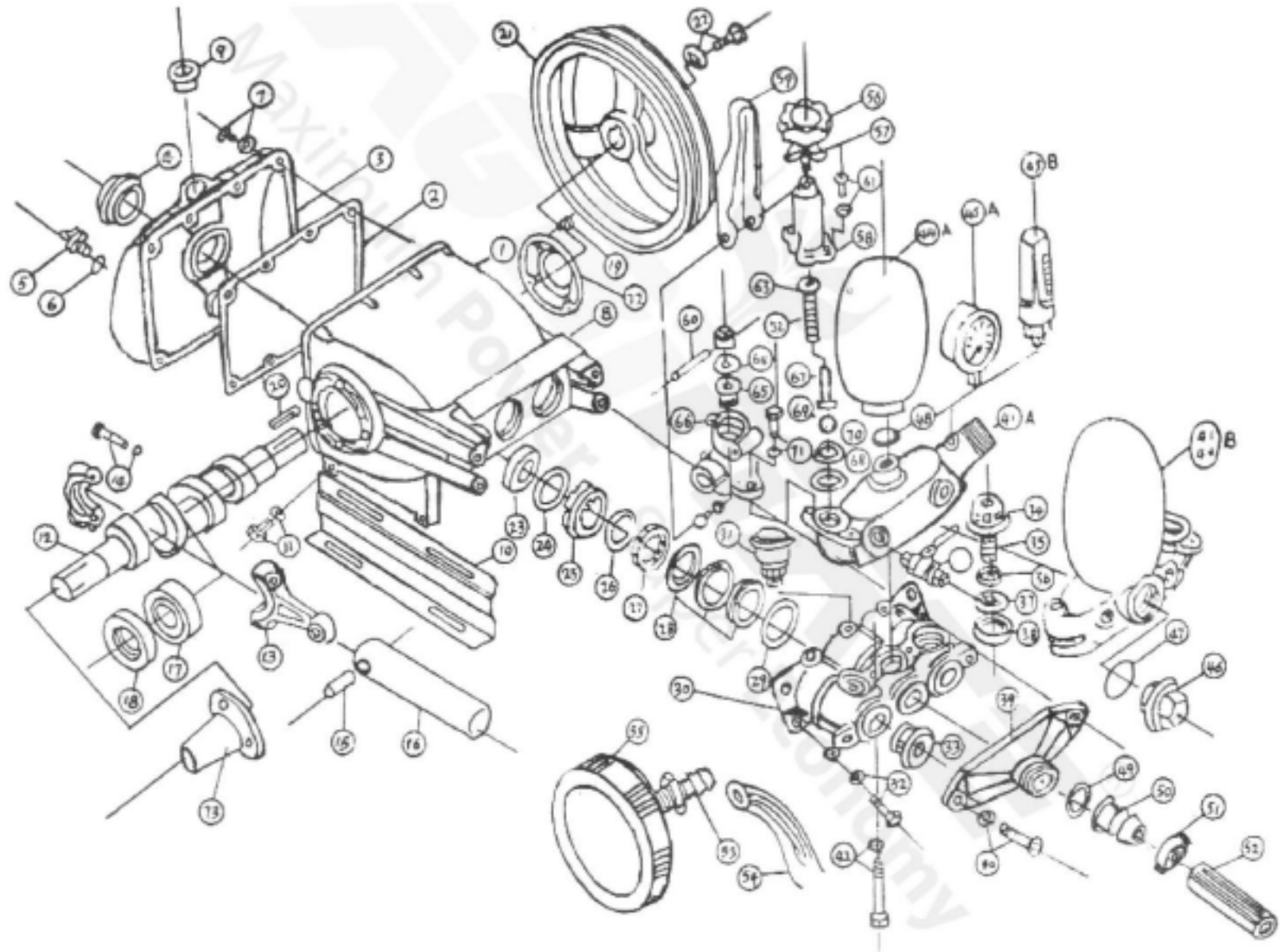

SPARE PARTS LIST OF AM-30K-MS+ HTP PUMP

SL. NO.	PART NUMBER	DESCRIPTION	SL. NO.	PART NUMBER	DESCRIPTION
1	AM-30K-1	Crank Case	17	AM-30K-17	Bearing
2	AM-30K-2	Gasket Crank Case	18	AM-30K-1s	Oil Seal crank Shaft
3	AM-30K-3	Cover Crank Case	19	AM-30K-19	Bolt
4	AM-30K-4	Oil Gauge	20	AM-30K-20	Key
5	AM-30K-5	Plug Drain	21	AM-30K-21	Pulley
6	AM-30K-6	O Ring	22	AM-30K-22	Bolt
7	AM-30K-7	Screw	23	AM-30K-23	Oil Seal Plunger
8	AM-30K-8	Plunger Cover	24	AM-30K-24	Stopping Ring Water
9	AM-30K-9	Plug	25	AM-30K-25	Grand
10	AM-30K-10	Red Crank Case	26	AM-30K-26	Crease Seal
11	AM-30K-11	Bolt Washer Spring	27	AM-30K-27	Crease Ring
12	AT-30K-12	Crank Shaft	28	AM-30K-28	V Packing
13	AM-30K-13	Connecting Rod	29	AM-30K-29	V Packing seat
14	AM-30K-14	Bolt Washer Spring	30K	AM-30K-30K	Cylinder
15	AM-30K-15	Plunger Pin	31	AM-30K-31	Grease Cup
16	AM-30K-16	Plunger	32	AM-30K-32	Bolt Wahser Spring

SPARE PARTS LIST OF AM-30K-MS+ HTP PUMP

SL. NO.	PART NUMBER	DESCRIPTION	SL. NO.	PART NUMBER	DESCRIPTION
33	AM-30K-33	Valve Assy	49	AM-30K-49	Packing
34	AM-30K-34	Valve Box	50	AM-30K-50	Core Coupling
35	AM-30K-35	Valve Spring	51	AM-30K-51	Coupling
36	AM-30K-36	Valve Flat	52	AM-30K-52	P.V.C Hose
37	AM-30K-37	Valve Seat	53	AM-30K-53	Core Strainer
38	AM-30K-38	Valve Seal	54	AM-30K-54	P.V.C Hose
39	AM-30K-39	Suction Metal	55	AM-30K-55	Strainer Assy
40	AM-30K-40	Bolt Washer Spring	56	AM-30K-56	Screw
41	AM-30K-41	Discharge Metal	57	AM-30K-57	Fly Nut
42	AM-30K-42	Bolt Washer Spring	58	AM-30K-58	Spring Box
43	AM-30K-43	Cock	59	AM-30K-59	Knob Control
44	AM-30K-44	Air Chamber	60	AM-30K-60	Pin
45	AM-30K-45	Pressure Gauge	61	AM-30K-61	Bolt Wahser Spring
46	AM-30K-46	Bolt Wahser Spring	62	AM-30K-62	Spring Box
47	AM-30K-47	O-Ring	63	AM-30K-63	Upper Metal
48	AM-30K-48	O-Ring	64	AM-30K-64	Packing

SPARE PARTS LIST OF AM-30K-MS+ HTP PUMP

SL. NO.	PART NUMBER	DESCRIPTION
65	AM-30K-65	Oil Seal
66	AM-30K-66	Body Over Flow
67	AM-30K-67	Spindle
68	AM-30K-68	Valve
69	AM-30K-69	O-Ring
70	AM-30K-70	valve Seat
71	AM-30K-71	Bolt Washer Spring
72	AM-30K-72	Cover Oil Seal
73	AM-30K-73	Cover Oil Seal
74	AM-30K-74	Cover Oil Seal

SPARE PARTS LIST OF AM-22K-MS+ HTP PUMP

SL. NO.	PART NUMBER	DESCRIPTION	SL. NO.	PART NUMBER	DESCRIPTION
1	AM-22K-1	Crank Case	17	AM-22K-17	Bearing
2	AM-22K-2	Gasket Crank Case	18	AM-22K-1s	Oil Seal crank Shaft
3	AM-22K-3	Cover Crank Case	19	AM-22K-19	Bolt
4	AM-22K-4	Oil Gauge	20	AM-22K-20	Key
5	AM-22K-5	Plug Drain	21	AM-22K-21	Pulley
6	AM-22K-6	O Ring	22	AM-22K-22	Bolt
7	AM-22K-7	Screw	23	AM-22K-23	Oil Seal Plunger
8	AM-22K-8	Plunger Cover	24	AM-22K-24	Stopping Ring Water
9	AM-22K-9	Plug	25	AM-22K-25	Grand
10	AM-22K-10	Red Crank Case	26	AM-22K-26	Crease Seal
11	AM-22K-11	Bolt Washer Spring	27	AM-22K-27	Crease Ring
12	AT-22K-12	Crank Shaft	28	AM-22K-28	V Packing
13	AM-22K-13	Connecting Rod	29	AM-22K-29	V Packing seat
14	AM-22K-14	Bolt Washer Spring	30	AM-22K-30K	Cylinder
15	AM-22K-15	Plunger Pin	31	AM-22K-31	Grease Cup
16	AM-22K-16	Plunger	32	AM-22K-32	Bolt Wahser Spring

SPARE PARTS LIST OF AM-22K-MS+ HTP PUMP

SL. NO.	PART NUMBER	DESCRIPTION	SL. NO.	PART NUMBER	DESCRIPTION
33	AM-22K-33	Valve Assy	49	AM-22K-49	Packing
34	AM-22K-34	Valve Box	50	AM-22K-50	Core Coupling
35	AM-22K-35	Valve Spring	51	AM-22K-51	Coupling
36	AM-22K-36	Valve Flat	52	AM-22K-52	P.V.C Hose
37	AM-22K-37	Valve Seat	53	AM-22K-53	Core Strainer
38	AM-22K-38	Valve Seal	54	AM-22K-54	P.V.C Hose
39	AM-22K-39	Suction Metal	55	AM-22K-55	Strainer Assy
40	AM-22K-40	Bolt Washer Spring	56	AM-22K-56	Screw
41	AM-22K-41	Discharge Metal	57	AM-22K-57	Fly Nut
42	AM-22K-42	Bolt Washer Spring	58	AM-22K-58	Spring Box
43	AM-22K-43	Cock	59	AM-22K-59	Knob Control
44	AM-22K-44	Air Chamber	60	AM-22K-60	Pin
45	AM-22K-45	Pressure Gauge	61	AM-22K-61	Bolt Wahser Spring
46	AM-22K-46	Bolt Wahser Spring	62	AM-22K-62	Spring Box
47	AM-22K-47	O-Ring	63	AM-22K-63	Upper Metal
48	AM-22K-48	O-Ring	64	AM-22K-64	Packing

SPARE PARTS LIST OF AM-22K-MS+ HTP PUMP

SL. NO.	PART NUMBER	DESCRIPTION	SL. NO.	PART NUMBER	DESCRIPTION
65	AM-22K-65	Oil Seal			
66	AM-22K-66	Body Over Flow			
67	AM-22K-67	Spindle			
68	AM-22K-68	Valve			
69	AM-22K-69	O-Ring			
70	AM-22K-70	valve Seat			
71	AM-22K-71	Bolt Washer Spring			
72	AM-22K-72	Cover Oil Seal			
73	AM-22K-73	Cover Oil Seal			
74	AM-22K-74	Cover Oil Seal			

INSPECTION & MAINTAINANCE

For safety use, make sure the machine is cleaned every three months. Before working, make sure to inspect the filter and the nozzle and ensure there is no impurity. After working, make sure there is no water in the pump and the hose.

If the machine needs to be repaired in the guarantee period, please return the machine to the shop. You need to provide the certificate of purchase on order to repair or get the substitute.

Before packing, the machine should be cleaned, then use closed packaging, packaging should be firm. Store the machine in dry place.

For transportation safety. The machine should comply with ISTA.





Do not dispose of electrical machines as unsorted municipal waste, use separate collection facilities.

If electrical machines are disposed of in landfills or dumps, hazardous substances can leak into the ground water and get into the food chain, damaging your health and well being.

When replacing old machines with new ones, the retailer is legally obligated to take back your old machine for disposals at least free of charge.





WARRANTY CARD

CUSTOMER COPY

DATE _____	DATE OF DELIVERY _____	DEALERS OFFICIAL SEAL	DEALERS SIGN _____
PURCHASERS NAME & ADDRESS _____ _____	 CUSTOMER SIGN		
PRODUCT NAME	PRODUCT SERIAL NO.	INVOICE/DN NO.	
			

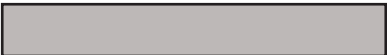



I/Will accept the terms and conditions of warranty as in the warranty card

DEALERS COPY

DATE _____	DATE OF DELIVERY _____	DEALERS OFFICIAL SEAL	DEALERS SIGN _____
PURCHASERS NAME & ADDRESS _____ _____	 CUSTOMER SIGN		
PRODUCT NAME	PRODUCT SERIAL NO.	INVOICE/DN NO.	
			

I/Will accept the terms and conditions of warranty as in the warranty card

COMPANY COPY

DATE _____	DATE OF DELIVERY _____	DEALERS OFFICIAL SEAL	DEALERS SIGN _____
PURCHASERS NAME & ADDRESS _____ _____	 CUSTOMER SIGN		
PRODUCT NAME	PRODUCT SERIAL NO.	INVOICE/DN NO.	
			

I/Will accept the terms and conditions of warranty as in the warranty card

1. LIMITED WARRANTY PERIOD : For a period of six months from the date of Sale / delivery of the product which ever is earlier. 2. LIMITED WARRANTY OBLIGATION : Replacement of defective part(s) by authorized dealer are free of charges. If found defective by reasons of defective material / poor workmanship, parts will be replaced and there will be no value re-imburement. 3. TERMS & CONDITIONS : a. Claims under warranty will be accepted on submission of Warranty Card duly filled and stamped by authorized dealer together with the original purchase document. : b. Shipping / transportation / Incidental charges incurred in replacing defective parts under warranty shall be borne by the purchaser

WARRANTY null & void if

- (i) Lack of maintenance, (ii) Incorrect use of the machine or tampering, (iii) Use of non-genuine spare parts, (iv) Usage of acids, solvents, or any flammable materials, (v) Non-usage of filter water / clear water / soft water & using water above 40°C temperature, (vi) While using the pressure washers to draw water which is contaminated with dust & solvents (eg. paint thinners, gasoline, oil, etc.), (vii) Repair done by unauthorized service people, (viii) Those parts subject to wear & tear due to normal operations and plastic parts, rubber items etc, (ix) Loose connections, faulty electrical fixtures & fluctuations in power supply.
- 4. Should any failure occur during or after the warranty period, customer does not have the right to interrupt payment / price discount.
- 5. Incidental or consequential damages like inconvenience commercial loss, loss of tie, mental agony etc.
- 6. Loss of any nature due to operation or non-operation is not covered under warranty.
- 7. All free service are at Dealer's service point only.
- 8. Warranty ceases if service is not done periodically.
- 9. The attached card should be completed and returned to Ratnagiri Impex Pvt. Ltd. for registration immediately after sale / delivery.
- 10. The warranty is void unless you register the warranty card with Ratnagiri Impex Pvt. Ltd.
- 11. The decision of Ratnagiri Impex Pvt. Ltd., in settling the warranty is final in all respects.
- 12. All disputes are subject to Bangalore Courts Jurisdiction

1. LIMITED WARRANTY PERIOD : For a period of six months from the date of Sale / delivery of the product which ever is earlier. 2. LIMITED WARRANTY OBLIGATION : Replacement of defective part(s) by authorized dealer are free of charges. If found defective by reasons of defective material / poor workmanship, parts will be replaced and there will be no value re-imburement. 3. TERMS & CONDITIONS : a. Claims under warranty will be accepted on submission of Warranty Card duly filled and stamped by authorized dealer together with the original purchase document. : b. Shipping / transportation / Incidental charges incurred in replacing defective parts under warranty shall be borne by the purchaser.

WARRANTY null & void if

- (i) Lack of maintenance, (ii) Incorrect use of the machine or tampering, (iii) Use of non-genuine spare parts, (iv) Usage of acids, solvents, or any flammable materials, (v) Non-usage of filter water / clear water / soft water & using water above 40°C temperature, (vi) While using the pressure washers to draw water which is contaminated with dust & solvents (eg. paint thinners, gasoline, oil, etc.), (vii) Repair done by unauthorized service people, (viii) Those parts subject to wear & tear due to normal operations and plastic parts, rubber items etc, (ix) Loose connections, faulty electrical fixtures & fluctuations in power supply.
- 4. Should any failure occur during or after the warranty period, customer does not have the right to interrupt payment / price discount.
- 5. Incidental or consequential damages like inconvenience commercial loss, loss of tie, mental agony etc.
- 6. Loss of any nature due to operation or non-operation is not covered under warranty.
- 7. All free service are at Dealer's service point only.
- 8. Warranty ceases if service is not done periodically.
- 9. The attached card should be completed and returned to Ratnagiri Impex Pvt. Ltd. for registration immediately after sale / delivery.
- 10. The warranty is void unless you register the warranty card with Ratnagiri Impex Pvt. Ltd.
- 11. The decision of Ratnagiri Impex Pvt. Ltd., in settling the warranty is final in all respects.
- 12. All disputes are subject to Bangalore Courts Jurisdiction

1. LIMITED WARRANTY PERIOD : For a period of six months from the date of Sale / delivery of the product which ever is earlier. 2. LIMITED WARRANTY OBLIGATION : Replacement of defective part(s) by authorized dealer are free of charges. If found defective by reasons of defective material / poor workmanship, parts will be replaced and there will be no value re-imburement. 3. TERMS & CONDITIONS : a. Claims under warranty will be accepted on submission of Warranty Card duly filled and stamped by authorized dealer together with the original purchase document. : b. Shipping / transportation / Incidental charges incurred in replacing defective parts under warranty shall be borne by the purchaser.

WARRANTY null & void if

- (i) Lack of maintenance, (ii) Incorrect use of the machine or tampering, (iii) Use of non-genuine spare parts, (iv) Usage of acids, solvents, or any flammable materials, (v) Non-usage of filter water / clear water / soft water & using water above 40°C temperature, (vi) While using the pressure washers to draw water which is contaminated with dust & solvents (eg. paint thinners, gasoline, oil, etc.), (vii) Repair done by unauthorized service people, (viii) Those parts subject to wear & tear due to normal operations and plastic parts, rubber items etc, (ix) Loose connections, faulty electrical fixtures & fluctuations in power supply.
- 4. Should any failure occur during or after the warranty period, customer does not have the right to interrupt payment / price discount.
- 5. Incidental or consequential damages like inconvenience commercial loss, loss of tie, mental agony etc.
- 6. Loss of any nature due to operation or non-operation is not covered under warranty.
- 7. All free service are at Dealer's service point only.
- 8. Warranty ceases if service is not done periodically.
- 9. The attached card should be completed and returned to Ratnagiri Impex Pvt. Ltd. for registration immediately after sale / delivery.
- 10. The warranty is void unless you register the warranty card with Ratnagiri Impex Pvt. Ltd.
- 11. The decision of Ratnagiri Impex Pvt. Ltd., in settling the warranty is final in all respects.
- 12. All disputes are subject to Bangalore Courts Jurisdiction



FREE SERVICE COUPON (30DAYS/30HRS. WHICHEVER IS EARLIER)

MODEL

SERIAL NUMBER

PDI DATE

SERVICE NO.

PURCHASE BILL NO.

DATE

DEALERS OFFICE SEAL

- 1. Check and test the fuel mixture
- 3. Check , clean and adjust the spark plug
- 5. Check and sparken the cutting tools
- 7. Start and check the noise, vibration, loosen etc..

OPERATIONS

- 2. check and clean the air filter
- 4. Check and adjust the carburetor tuning
- 6. Product familirisation on usage
- 8. Routine maintenance and shortage.

FREE SERVICE COUPON (30DAYS/30HRS. WHICHEVER IS EARLIER)

MODEL

SERIAL NUMBER

PDI DATE

SERVICE NO.

PURCHASE BILL NO.

DATE

DEALERS OFFICE SEAL

- 1. Check and test the fuel mixture
- 3. Check , clean and adjust the spark plug
- 5. Check and sparken the cutting tools
- 7. Start and check the noise, vibration, loosen etc..

OPERATIONS

- 2. check and clean the air filter
- 4. Check and adjust the carburetor tuning
- 6. Product familirisation on usage
- 8. Routine maintenance and shortage.

FREE SERVICE COUPON (30DAYS/30HRS. WHICHEVER IS EARLIER)

MODEL

SERIAL NUMBER

PDI DATE

SERVICE NO.

PURCHASE BILL NO.

DATE

DEALERS OFFICE SEAL

- 1. Check and test the fuel mixture
- 3. Check , clean and adjust the spark plug
- 5. Check and sparken the cutting tools
- 7. Start and check the noise, vibration, loosen etc..

OPERATIONS

- 2. check and clean the air filter
- 4. Check and adjust the carburetor tuning
- 6. Product familirisation on usage
- 8. Routine maintenance and shortage.

DOS

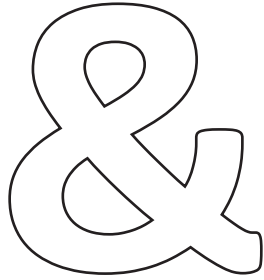

DONT'S

1. Always read the instruction manual supplied along with the equipments and understand the correct installation and operating procedures before attempting to use the equipments.
2. It is important to use the personal protection equipments such as head helmet with visor, ear defenders, goggles, safety gloves, cut resistant shoes, trousers and jackets while operating potentially dangerous machines
3. Avoid untrained persons using the equipments. Children must not be allowed to handle these equipments
4. Always use genuine spares and accessories in repairs and usage to derive maximum life of the equipments.
5. Always keep the equipments in good working condition to minimize loss of output as well as to reduce the pollution and save the environment
6. Do not use the machine within range of persons unless they wear protective clothing
7. Do not operate the machine when fatigued or under the influence of alcohol or drugs
8. When the machine is running, please maintain a constant water supply. Without water circulation will damage the sealing rings of the machine.
9. For more query kindly contact for our Service Center/Dealer/ franchise

AGRIMATE MULTI PURPOSE EQUIPMENT ANYWHERE - ANYTIME - ANY CROP

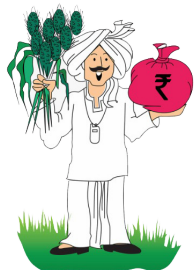
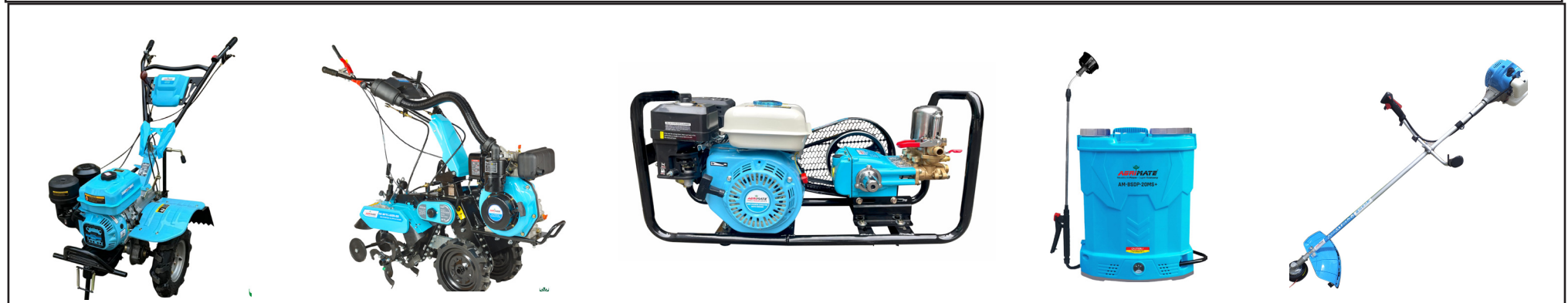

**ratnagiri[®]
impex**
BRINGING YOU THE FUTURE... NOW

IMPORTED & MARKETING BY,
RATNAGIRI IMPEX PVT., LTD.,
Annapurna House, #1 / 1G, 7th Cross, New
Guddadahalli Mysore Road, Bangalore - 560 026
Missed Call : 7393 938 938 Email: ask@agrimart.in