

AGRIMATE CHAFF CUTTER
AM-CCM-400-1.5K



TECHNICAL SPECIFICATIONS

MODEL	AM-CCM-400-1.5K
RATED POWER	3HP
SPINDLE SPEED	1400RPM
RATED VOLTAGE	220V, 50HZ
RPM MOTOR	2800RPM
PRODUCTIVITY (KG/H)	1500

Problem	Cause	Troubleshooting
High machine vibration or strong noise	<ol style="list-style-type: none"> 1. Bearing damage 2. Spindle bending and deformation 3. Loose connection 4. The weight difference between the structural parts of the two sets of guillotine knives 	<ol style="list-style-type: none"> 1. Replacement of bearings 2. Replace the spindle 3. Tighten the linkage 4. Replacement of symmetrical guillotine structural parts
Difficulty in starting and overheating of the motor or weakness in starting and working of the motor	<ol style="list-style-type: none"> 1. Voltage is too low 2. The cross-sectional area of the wire is too small 3. The fuse is easy to blow 4. Long time overload 5. The motor capacitor is damaged 	<ol style="list-style-type: none"> 1. Avoid the peak of electricity consumption before starting 2. Change the wire with appropriate cross-sectional area 3. Change the fuse to match the capacity of the motor 4. Work under rated load 5. Replace the electric
Overheating of bearings	<ol style="list-style-type: none"> 1. Excessive grease or poor lubrication 2. Bearing damage 3. Bent spindle or unbalanced rotor 4. Dirt or foreign matter enters the bearing 5. Triangle belt is too tight 	<ol style="list-style-type: none"> 1. Replacement and filling with suitable amount of grease 2. Replacement of bearings 3. Replace the spindle and balance the rotor 4. Clean the bearings, replace the oil seal 5. Adjust the tension of v-belt
Noises in the working chamber	<ol style="list-style-type: none"> 1. Metal, stones and other hard objects enter the machine 2. There are parts in the body that are damaged or fall off 	<ol style="list-style-type: none"> 1. Stop the machine to check and remove debris 2. Stop the machine to check and replace parts
Too low yield	<ol style="list-style-type: none"> 1. Voltage is too low, motor power is not enough 2. Serious wear of guillotine knife (guillotine machine) 3. Uneven feeding or too slow 4. Turns too low or belt slipping 	<ol style="list-style-type: none"> 1. Avoid working at peak electricity consumption 2. Sharpen or replace guillotine knives 3. Feed evenly and run at full load 4. Ensure the number of revolutions and tighten the belt
Finished product too coarse	Gap between guillotine knives is too large	Adjust the gap between the fixed and moving knives of the guillotine to less than 0.3mm and without collision
Belt heating	<ol style="list-style-type: none"> 1. Triangle belt is too loose 2. The v-belt is worn 	<ol style="list-style-type: none"> 1. Adjust the elasticity appropriately 2. Replace the v-belt

1. Before using the machine, carefully read the contents of the instruction manual and warning signs, and use, adjust and maintain it safely.
2. The user can match the power according to the actual needs, and the safety protection device must be installed when installing and using the matching power.
3. The user should configure the overload protection device and the ground wire by himself, and the motor must be reliably grounded.
4. The machine must run in the specified direction of rotation, overload operation is prohibited, tight clothing must be worn during operation, cuffs must be tightened, and personnel must not be approached during work.
5. Before operation, check whether the parts of the machine are installed and intact, whether the connecting parts are tight, whether the moving parts are flexible, and whether the gap between the parts meets the requirements.
6. When feeding, the operator should stand on the side of the feeding port without rotating parts, and prohibit iron, hard debris and reaching into it!

7. It is forbidden for minors, the disabled and the elderly over 55 to operate the machine! It is strictly forbidden to operate the machine after drinking, sick or over-fatigued.

8. The power supply must be cut off when troubleshooting and adjusting or replacing parts and wearing parts to ensure safety. It is strictly forbidden to open the door or the cover when the machine is not stopped.

9. If abnormal noise occurs during operation, the power supply should be cut off immediately, and the machine should be shut down for inspection. It is strictly forbidden to remove blockages by hand or iron rods at the feeding port and discharge port when the machine is running.

10. When working, pay attention that the bearing temperature should not exceed 55. If there is overheating, stop and check immediately to avoid burning the bearing, spindle, etc.

SPARE PARTS DIAGRAM & SPARE PARTS LIST OF AM-CCM-400-1.5K

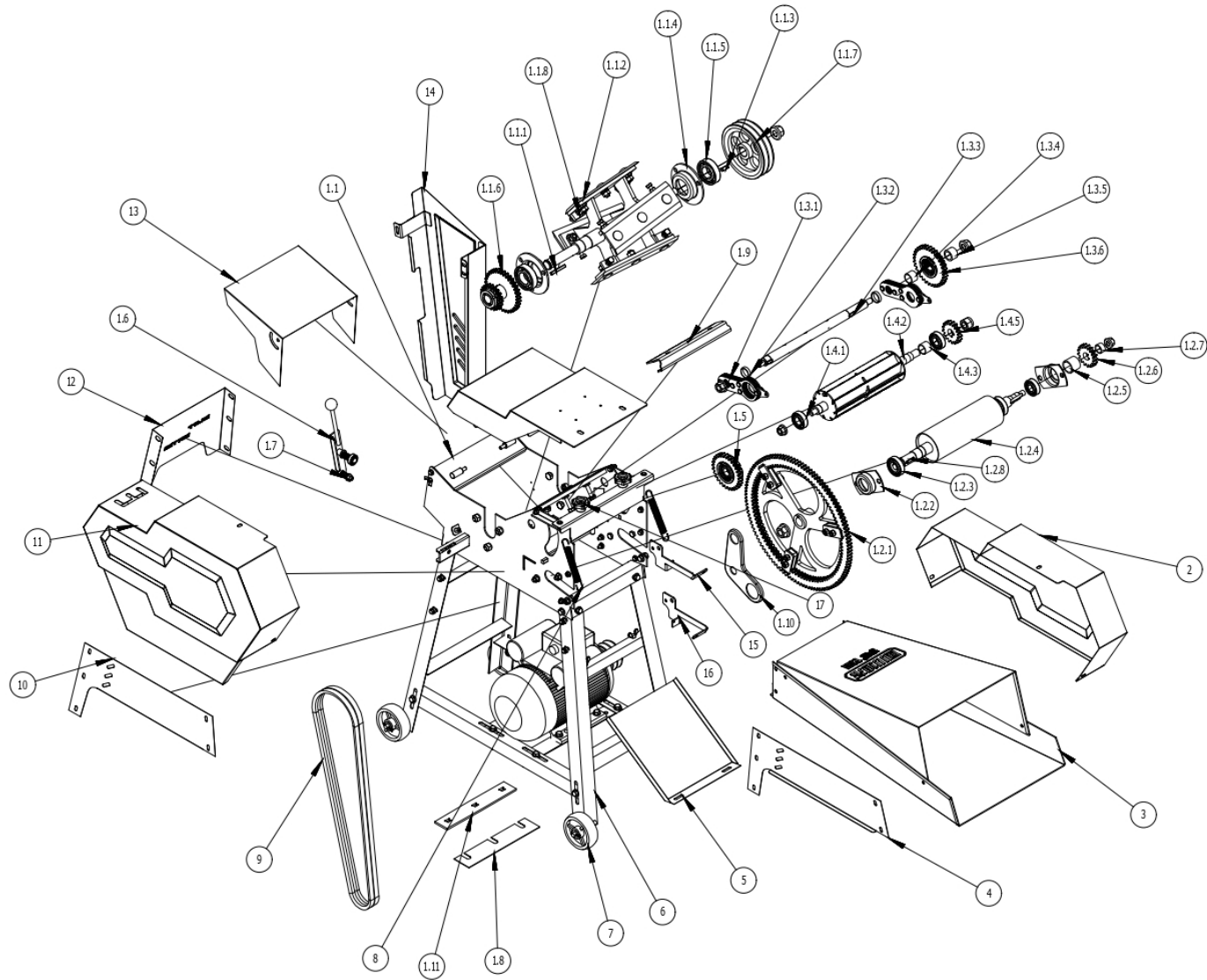

SL NO	PART NO	DESCRIPTION	SL NO	PART NO	DESCRIPTION
1.1	AM-CCM-400-1.5K-1.1	Machine Cover	1.1.1	AM-CCM-400-1.5K-1.1.1	Key
1.5	AM-CCM-400-1.5K-1.5	Idle Gear Assy	1.1.2	AM-CCM-400-1.5K-1.1.2	Fixed blade
1.6	AM-CCM-400-1.5K-1.6	Shift lever	1.1.3	AM-CCM-400-1.5K-1.1.3	Key
1.7	AM-CCM-400-1.5K-1.7	Shift gear Spring	1.1.4	AM-CCM-400-1.5K-1.1.4	Main roller bearing Block
1.8	AM-CCM-400-1.5K-1.8	Smooth Roller Scraper Board	1.1.5	AM-CCM-400-1.5K-1.1.5	Bearing
1.9	AM-CCM-400-1.5K-1.9	U shaped Grass Block	1.1.6	AM-CCM-400-1.5K-1.1.6	Biqeminal Tooth
1.1	AM-CCM-400-1.5K-1.10	Gear Shaft reinforcing Plate	1.1.7	AM-CCM-400-1.5K-1.1.7	Machine Pulley
1.11	AM-CCM-400-1.5K-1.11	Fixed blade	1.1.8	AM-CCM-400-1.5K-1.1.8	Blade backstop plate
1.2.1	AM-CCM-400-1.5K-1.2.1	Big gear Assy	1.3.1	AM-CCM-400-1.5K-1.3.1	Connecting plate
1.2.2	AM-CCM-400-1.5K-1.2.2	Small Roller Bearing block	1.3.2	AM-CCM-400-1.5K-1.3.2	Roller connecting rod Sleeve
1.2.3	AM-CCM-400-1.5K-1.2.3	Bearing	1.3.3	AM-CCM-400-1.5K-1.3.3	Key
1.2.4	AM-CCM-400-1.5K-1.2.4	Smooth Roller	1.3.4	AM-CCM-400-1.5K-1.3.4	Tooth Roller Bush
1.2.5	AM-CCM-400-1.5K-1.2.5	Smooth Roller Gear Mounting Sleeve	1.3.5	AM-CCM-400-1.5K-1.3.5	Idler Connecting Rod
1.2.6	AM-CCM-400-1.5K-1.2.6	Gear	1.3.6	AM-CCM-400-1.5K-1.3.6	Idle Gear Assy
1.2.7	AM-CCM-400-1.5K-1.2.7	Idler Connecting Sleeve 2	1.4.1	AM-CCM-400-1.5K-1.4.1	Gear
1.2.8	AM-CCM-400-1.5K-1.2.8	Key	1.4.2	AM-CCM-400-1.5K-1.4.2	Tooth roller bush welding assy

SL NO	PART NO	DESCRIPTION	SL NO	PART NO	DESCRIPTION
1.4.3	AM-CCM-400-1.5K-1.4.3	Tooth roller bush	11	AM-CCM-400-1.5K-11	Belt cover left
1.4.5	AM-CCM-400-1.5K-1.4.5	Gear	12	AM-CCM-400-1.5K-12	Baffle plate with laser cutting
2	AM-CCM-400-1.5K-02	Belt Gear Right	13	AM-CCM-400-1.5K-13	Outlet cover
3	AM-CCM-400-1.5K-03	Feed Hopper	14	AM-CCM-400-1.5K-14	Belt Cover assy
4	AM-CCM-400-1.5K-04	Baffle plate	15	AM-CCM-400-1.5K-15	Cover connection part
5	AM-CCM-400-1.5K-05	Screap Grass Collecting board	16	AM-CCM-400-1.5K-16	Cover connection part
7	AM-CCM-400-1.5K-07	Wheel	17	AM-CCM-400-1.5K-17	Handle Wheel
8	AM-CCM-400-1.5K-08	Tooth Roller Spring			
9	AM-CCM-400-1.5K-09	Belt			
10	AM-CCM-400-1.5K-10	Baffle plate			

INSPECTION & MAINTAINANCE

For safety use, make sure the machine is cleaned every three months. Before working, make sure to inspect the filter and the nozzle and ensure there is no impurity. After working, make sure there is no water in the pump and the hose.

If the machine needs to be repaired in the guarantee period, please return the machine to the shop. You need to provide the certificate of purchase on order to repair or get the substitute.

Before packing, the machine should be cleaned, then use closed packaging, packaging should be firm. Store the machine in dry place.

For transportation safety. The machine should comply with ISTA.





Do not dispose of electrical machines as unsorted municipal waste, use separate collection facilities.

If electrical machines are disposed of in landfills or dumps, hazardous substances can leak into the ground water and get into the food chain, damaging your health and well being.

When replacing old machines with new ones, the retailer is legally obligated to take back your old machine for disposals at least free of charge.





WARRANTY CARD

CUSTOMER COPY

DATE _____	DATE OF DELIVERY _____	DEALERS OFFICIAL SEAL	DEALERS SIGN _____
PURCHASERS NAME & ADDRESS _____ _____	 CUSTOMER SIGN		
PRODUCT NAME	PRODUCT SERIAL NO.	INVOICE/DN NO.	
			

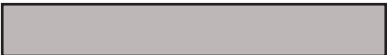



I/Will accept the terms and conditions of warranty as in the warranty card

DEALERS COPY

DATE _____	DATE OF DELIVERY _____	DEALERS OFFICIAL SEAL	DEALERS SIGN _____
PURCHASERS NAME & ADDRESS _____ _____	 CUSTOMER SIGN		
PRODUCT NAME	PRODUCT SERIAL NO.	INVOICE/DN NO.	
			

I/Will accept the terms and conditions of warranty as in the warranty card

COMPANY COPY

DATE _____	DATE OF DELIVERY _____	DEALERS OFFICIAL SEAL	DEALERS SIGN _____
PURCHASERS NAME & ADDRESS _____ _____	 CUSTOMER SIGN		
PRODUCT NAME	PRODUCT SERIAL NO.	INVOICE/DN NO.	
			

I/Will accept the terms and conditions of warranty as in the warranty card

1. LIMITED WARRANTY PERIOD : For a period of six months from the date of Sale / delivery of the product which ever is earlier. 2. LIMITED WARRANTY OBLIGATION : Replacement of defective part(s) by authorized dealer are free of charges. If found defective by reasons of defective material / poor workmanship, parts will be replaced and there will be no value re-imburement. 3. TERMS & CONDITIONS : a. Claims under warranty will be accepted on submission of Warranty Card duly filled and stamped by authorized dealer together with the original purchase document. : b. Shipping / transportation / Incidental charges incurred in replacing defective parts under warranty shall be borne by the purchaser

WARRANTY null & void if

- (i) Lack of maintenance, (ii) Incorrect use of the machine or tampering, (iii) Use of non-genuine spare parts, (iv) Usage of acids, solvents, or any flammable materials, (v) Non-usage of filter water / clear water / soft water & using water above 40°C temperature, (vi) While using the pressure washers to draw water which is contaminated with dust & solvents (eg. paint thinners, gasoline, oil, etc.), (vii) Repair done by unauthorized service people, (viii) Those parts subject to wear & tear due to normal operations and plastic parts, rubber items etc, (ix) Loose connections, faulty electrical fixtures & fluctuations in power supply.
- 4. Should any failure occur during or after the warranty period, customer does not have the right to interrupt payment / price discount.
- 5. Incidental or consequential damages like inconvenience commercial loss, loss of tie, mental agony etc.
- 6. Loss of any nature due to operation or non-operation is not covered under warranty.
- 7. All free service are at Dealer's service point only.
- 8. Warranty ceases if service is not done periodically.
- 9. The attached card should be completed and returned to Ratnagiri Impex Pvt. Ltd. for registration immediately after sale / delivery.
- 10. The warranty is void unless you register the warranty card with Ratnagiri Impex Pvt. Ltd.
- 11. The decision of Ratnagiri Impex Pvt. Ltd., in settling the warranty is final in all respects.
- 12. All disputes are subject to Bangalore Courts Jurisdiction

1. LIMITED WARRANTY PERIOD : For a period of six months from the date of Sale / delivery of the product which ever is earlier. 2. LIMITED WARRANTY OBLIGATION : Replacement of defective part(s) by authorized dealer are free of charges. If found defective by reasons of defective material / poor workmanship, parts will be replaced and there will be no value re-imburement. 3. TERMS & CONDITIONS : a. Claims under warranty will be accepted on submission of Warranty Card duly filled and stamped by authorized dealer together with the original purchase document. : b. Shipping / transportation / Incidental charges incurred in replacing defective parts under warranty shall be borne by the purchaser.

WARRANTY null & void if

- (i) Lack of maintenance, (ii) Incorrect use of the machine or tampering, (iii) Use of non-genuine spare parts, (iv) Usage of acids, solvents, or any flammable materials, (v) Non-usage of filter water / clear water / soft water & using water above 40°C temperature, (vi) While using the pressure washers to draw water which is contaminated with dust & solvents (eg. paint thinners, gasoline, oil, etc.), (vii) Repair done by unauthorized service people, (viii) Those parts subject to wear & tear due to normal operations and plastic parts, rubber items etc, (ix) Loose connections, faulty electrical fixtures & fluctuations in power supply.
- 4. Should any failure occur during or after the warranty period, customer does not have the right to interrupt payment / price discount.
- 5. Incidental or consequential damages like inconvenience commercial loss, loss of tie, mental agony etc.
- 6. Loss of any nature due to operation or non-operation is not covered under warranty.
- 7. All free service are at Dealer's service point only.
- 8. Warranty ceases if service is not done periodically.
- 9. The attached card should be completed and returned to Ratnagiri Impex Pvt. Ltd. for registration immediately after sale / delivery.
- 10. The warranty is void unless you register the warranty card with Ratnagiri Impex Pvt. Ltd.
- 11. The decision of Ratnagiri Impex Pvt. Ltd., in settling the warranty is final in all respects.
- 12. All disputes are subject to Bangalore Courts Jurisdiction

1. LIMITED WARRANTY PERIOD : For a period of six months from the date of Sale / delivery of the product which ever is earlier. 2. LIMITED WARRANTY OBLIGATION : Replacement of defective part(s) by authorized dealer are free of charges. If found defective by reasons of defective material / poor workmanship, parts will be replaced and there will be no value re-imburement. 3. TERMS & CONDITIONS : a. Claims under warranty will be accepted on submission of Warranty Card duly filled and stamped by authorized dealer together with the original purchase document. : b. Shipping / transportation / Incidental charges incurred in replacing defective parts under warranty shall be borne by the purchaser.

WARRANTY null & void if

- (i) Lack of maintenance, (ii) Incorrect use of the machine or tampering, (iii) Use of non-genuine spare parts, (iv) Usage of acids, solvents, or any flammable materials, (v) Non-usage of filter water / clear water / soft water & using water above 40°C temperature, (vi) While using the pressure washers to draw water which is contaminated with dust & solvents (eg. paint thinners, gasoline, oil, etc.), (vii) Repair done by unauthorized service people, (viii) Those parts subject to wear & tear due to normal operations and plastic parts, rubber items etc, (ix) Loose connections, faulty electrical fixtures & fluctuations in power supply.
- 4. Should any failure occur during or after the warranty period, customer does not have the right to interrupt payment / price discount.
- 5. Incidental or consequential damages like inconvenience commercial loss, loss of tie, mental agony etc.
- 6. Loss of any nature due to operation or non-operation is not covered under warranty.
- 7. All free service are at Dealer's service point only.
- 8. Warranty ceases if service is not done periodically.
- 9. The attached card should be completed and returned to Ratnagiri Impex Pvt. Ltd. for registration immediately after sale / delivery.
- 10. The warranty is void unless you register the warranty card with Ratnagiri Impex Pvt. Ltd.
- 11. The decision of Ratnagiri Impex Pvt. Ltd., in settling the warranty is final in all respects.
- 12. All disputes are subject to Bangalore Courts Jurisdiction



FREE SERVICE COUPON (30DAYS/30HRS. WHICHEVER IS EARLIER)

MODEL

SERIAL NUMBER

PDI DATE

SERVICE NO.

PURCHASE BILL NO.

DATE

DEALERS OFFICE SEAL

- 1. Check and test the fuel mixture
- 3. Check , clean and adjust the spark plug
- 5. Check and sparken the cutting tools
- 7. Start and check the noise, vibration, loosen etc..

OPERATIONS

- 2. check and clean the air filter
- 4. Check and adjust the carburetor tuning
- 6. Product familirisation on usage
- 8. Routine maintenance and shortage.

FREE SERVICE COUPON (30DAYS/30HRS. WHICHEVER IS EARLIER)

MODEL

SERIAL NUMBER

PDI DATE

SERVICE NO.

PURCHASE BILL NO.

DATE

DEALERS OFFICE SEAL

- 1. Check and test the fuel mixture
- 3. Check , clean and adjust the spark plug
- 5. Check and sparken the cutting tools
- 7. Start and check the noise, vibration, loosen etc..

OPERATIONS

- 2. check and clean the air filter
- 4. Check and adjust the carburetor tuning
- 6. Product familirisation on usage
- 8. Routine maintenance and shortage.

FREE SERVICE COUPON (30DAYS/30HRS. WHICHEVER IS EARLIER)

MODEL

SERIAL NUMBER

PDI DATE

SERVICE NO.

PURCHASE BILL NO.

DATE

DEALERS OFFICE SEAL

- 1. Check and test the fuel mixture
- 3. Check , clean and adjust the spark plug
- 5. Check and sparken the cutting tools
- 7. Start and check the noise, vibration, loosen etc..

OPERATIONS

- 2. check and clean the air filter
- 4. Check and adjust the carburetor tuning
- 6. Product familirisation on usage
- 8. Routine maintenance and shortage.

DOS

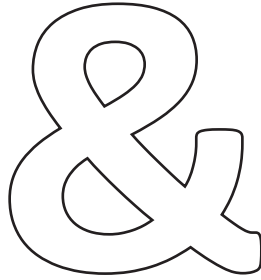

DONTs

1. Always read the instruction manual supplied along with the equipments and understand the correct installation and operating procedures before attempting to use the equipments.
2. It is important to use the personal protection equipments such as head helmet with visor, ear defenders, goggles, safety gloves, cut resistant shoes, trousers and jackets while operating potentially dangerous machines
3. Avoid untrained persons using the equipments. Children must not be allowed to handle these equipments
4. Always use genuine spares and accessories in repairs and usage to derive maximum life of the equipments.
5. Always keep the equipments in good working condition to minimize loss of output as well as to reduce the pollution and save the environment
6. Do not use the machine within range of persons unless they wear protective clothing
7. Do not operate the machine when fatigued or under the influence of alcohol or drugs
8. When the machine is running, please maintain a constant water supply. Without water circulation will damage the sealing rings of the machine.
9. For more query kindly contact for our Service Center/Dealer/ franchise

Agrimate Army For Pest Control

ANY WHERE - ANY TIME - ANY CROP

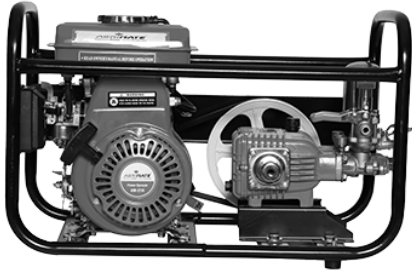
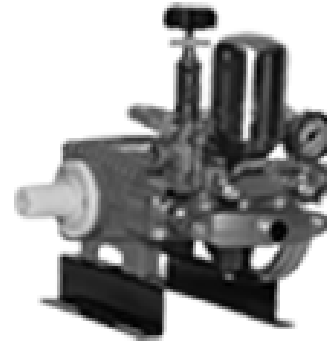

Marketed by:
**ratnagiri
impex**
BRINGING YOU THE FUTURE... NOW

IMPORTED & MARKETED BY,
RATNAGIRI IMPEX PVT., LTD.,

Annapurna House, #1 / 1G, 7th Cross, New
Guddadahalli Mysore Road, Bangalore - 560 026

Missed Call : 7393 938 938 Email: ask@agrimart.in