

HIGH PRESSURE PUMP WITH MOTOR AM-HPW-22MS+

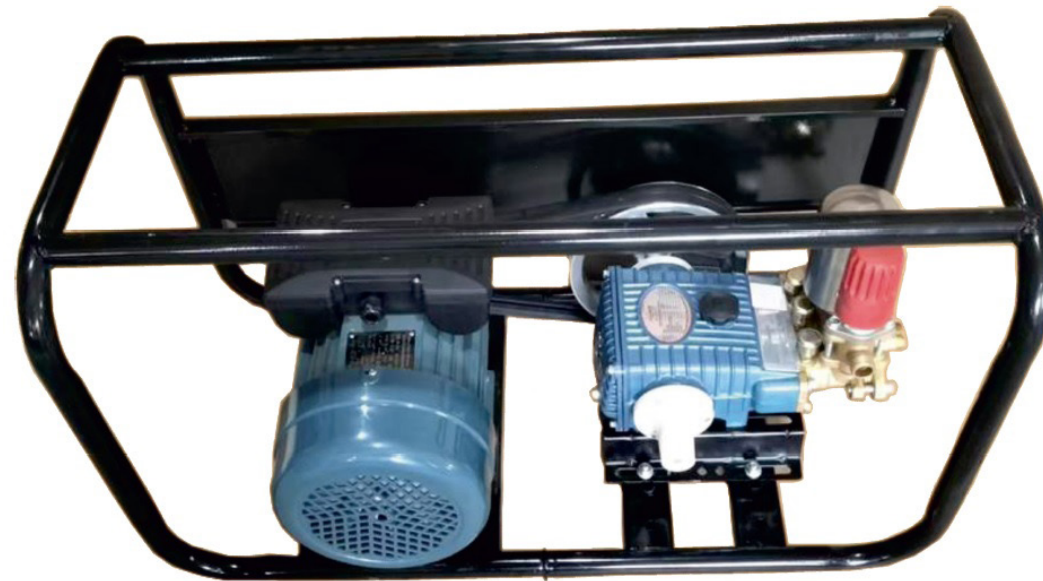

DISCLAIMER : DUE TO CONTANT UPGRADATION FEATURES & SPECIFICATIONS ARE SELECT TO CHANGE WITHOUT NOTICE
BEFORE OPERATING THIS MACHINE PLEASE READ THIS INSTRUCTIONS MANUAL CAREFULLY

INTRODUCTION

Please peruse the contents in the instructions manual prior to using this machine, correctly carried out installation and debugging, as well as used it strictly according to the working specifications in the instruction manual. The user should be familiar with the safety notices, machine performance and maintenance, etc. The instruction manual will be used in the later use, repair, accessories replacement, and accessories procurement, so please keep it carefully.

OPERATING INSTRUCTION

1. Securely mount the machine on the frame, ensured the two belt pulleys be parallel and on the same plane, and the tension of belt be moderate.
2. Add 30~ 40# machine oil upto 1/2 of oil gauge plug
3. The connectors of each rubber pipe and high pressure pipe must be locked tightly.
4. Before start the motor, open the jet gun and ball cock and loosen the adjusting screw
5. Start the motor , keeping it at appropriate velocity, waiting there is water ejecting from the jet gun, close the jet gun or ball cock, and adjust screw to let the pressure reach the working pressure.
6. Turn on the ball cock and jet gun, beginning spraying. During the process may properly adjust the adjusting screw to maintain the required pressure and lock tightly the fly nut at any moment.
7. After spraying, operate the sprayer with clean water for 2`3 minutes to clean the residual interior chemicals.
8. Firstly dismantle the suction hose, waiting there is no water flowing out from the jet gun or the overflow hose, stop the machine and dismantle overflow hose, high pressure pipe and loosen the adjusting screw.

TECHNICAL PARAMETERS

AMCL-22T POWER SPRAYER

RPM	500-900
FLOW(L/MIN)	10-15
WORKING PRESSURE(KGF/CM ²)	20-35
POWER (HP)	2-3
PISTON DIA (MM)	22
STROKE(MM)	16
A QUALITY PRODUCT - TAIWAN JOINT VENTURE	

MAINTANANCE & SERVICE

1. Replace the oil after begin use for 40hours and then replace it one time using each 70hours.
2. Add grease one time each two hours during using
3. After each work finished, operate it with clean water for 2~3 hours.
4. For long term placement, wipe clean the sprayer machine and place it at the cool and dry place.

SAFETY NOTICES

1. Using this machine extra high pressure is prohoboted
2. The belt pulley should have safety preotctive device
3. Should wear such protective tools as breating mask while spraying toward personnel and working at the downwind position are prohibited.
4. Running withot water or lubricating oil is prohibited
5. Using such special working solutions as strong acid, strong alkali, etc. is prohibited, and should operate strictly according to the safety prompts of manufacturing plant in spraying.

ACCESSORIES

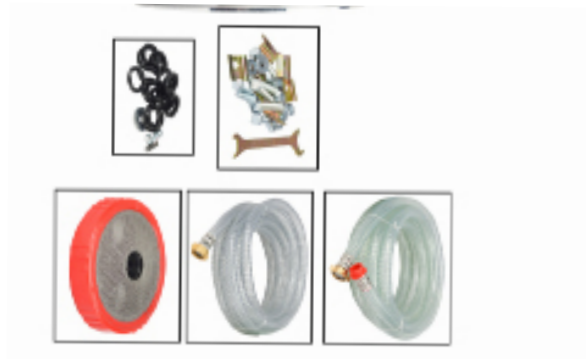

PART DIAGRAM OF AMCL-22T POWER SPRAYER

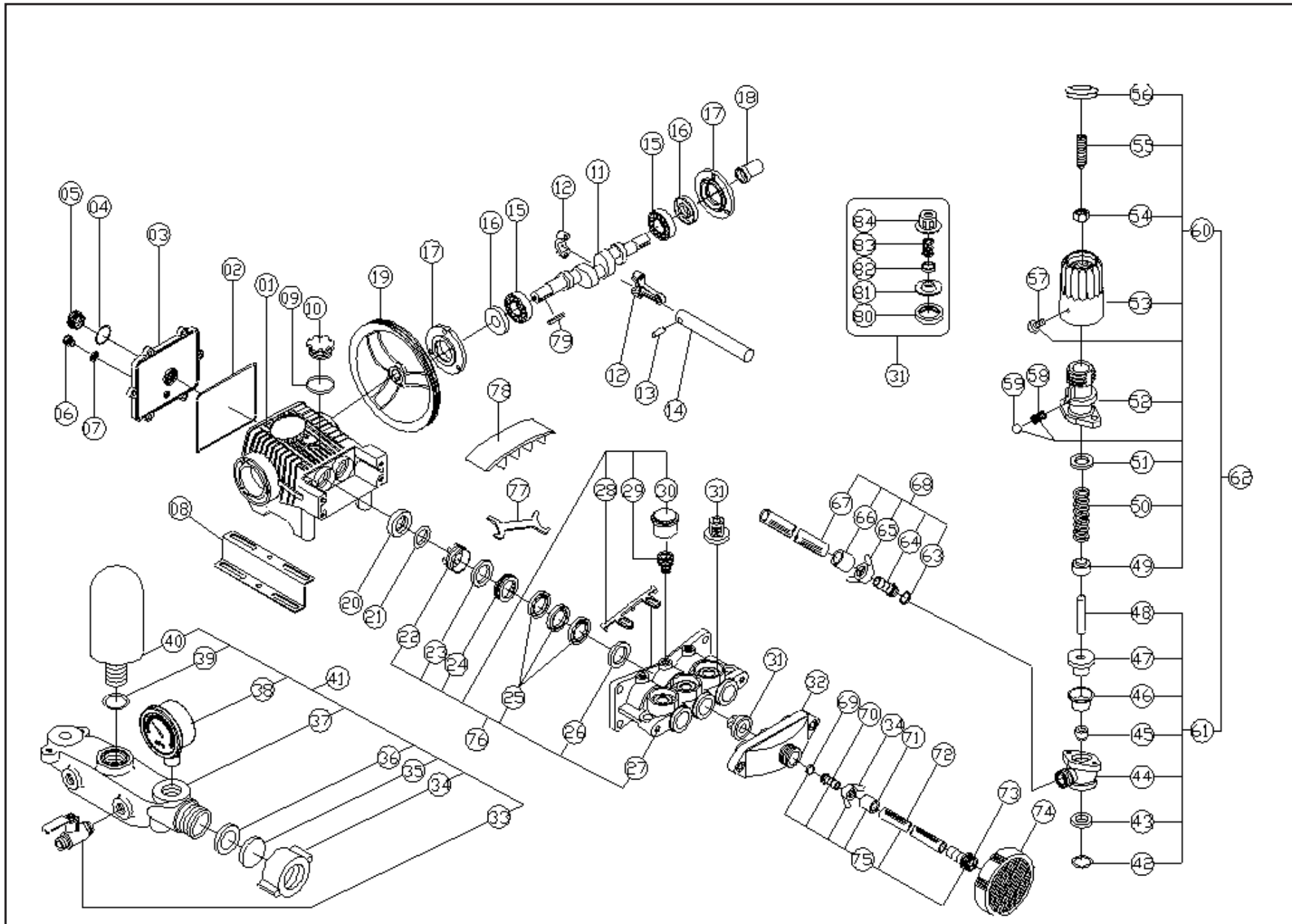

PART LIST OF AMCL-22T HTP POWER SPRAYER

SL NO	PART NO	DESCRIPTION	SL NO	PART NO	DESCRIPTION
1	AMCL-22T-01	Crank Case	17	AM-CL-22T-17	Cover,Oil Seal
2	AM-CL-22T-02	Ring CrankCase	18	AM-CL-22T-18	Cover,Shaft
3	AM-CL-22T-03	Cover CrankCase	19	AM-CL-22T-19	Pully
4	AM-CL-22T-04	O-Ring	20	AM-CL-22T-20	Oil Seal,Plunger
5	AM-CL-22T-05	Oil Gauge Plug	21	AM-CL-22T-21	Seal,Stopping Water
6	AM-CL-22T-06	Oil Plug	22	AM-CL-22T-22	Grand
7	AM-CL-22T-07	Ring	23	AM-CL-22T-23	O-Ring
8	AM-CL-22T-08	Oil Plug	24	AM-CL-22T-24	Grease Ring
9	AM-CL-22T-09	Bed CrankCase	25	AM-CL-22T-25	V-Packing
10	AM-CL-22T-10	Plunger Cover	26	AM-CL-22T-26	V-Packing Seat
11	AM-CL-22T-11	Crank Shaft	27	AM-CL-22T-27	Cylinder
12	AM-CL-22T-12	Connecting Rod	28	AM-CL-22T-28	Packing Stable Plate
13	AM-CL-22T-13	Plunger Pin	29	AM-CL-22T-29	Grease Cup(seat)
14	AM-CL-22T-14	Plunger	30	AM-CL-22T-30	Grease Cup(head)
15	AM-CL-22T-15	Bearing	31	AM-CL-22T-31	Valve Assy
16	AM-CL-22T-16	crankshaft oil seal	32	AM-CL-22T-32	Suction Metal

PART LIST OF AMCL-22T HTP POWER SPRAYER

SL NO	PART NO	DESCRIPTION	SL NO	PART NO	DESCRIPTION
33	AM-CL-22T-33	Ball Cock	50	AM-CL-22T-50	Spring
34	AM-CL-22T-34	Wing Net	51	AM-CL-22T-51	Upper Metal
35	AM-CL-22T-35	Washer	52	AM-CL-22T-52	Spring Box
36	AM-CL-22T-36	Ring	53	AM-CL-22T-53	Adjusting Screw
37	AM-CL-22T-37	Discharge Metal	54	AM-CL-22T-54	Nut
38	AM-CL-22T-38	Pressure Gauge	55	AM-CL-22T-55	Screw
39	AM-CL-22T-39	O-Ring	56	AM-CL-22T-56	Handle Cover
40	AM-CL-22T-40	Air Chamber	57	AM-CL-22T-57	Screw
41	AM-CL-22T-41	Discharge Metal Assy	58	AM-CL-22T-58	Spring
42	AM-CL-22T-42	O-Ring	59	AM-CL-22T-59	Ball bearing
43	AM-CL-22T-43	Valve Seat	60	AM-CL-22T-60	Adjusting Screw Assy
44	AM-CL-22T-44	Body Overflow	61	AM-CL-22T-61	Body Overflow Assy
45	AM-CL-22T-45	Valve	62	AM-CL-22T-62	Adjusting Assy
46	AM-CL-22T-46	Water Seal Cup	63	AM-CL-22T-63	O-Ring
47	AM-CL-22T-47	Box Water Seal	64	AM-CL-22T-64	Core Coupling
48	AM-CL-22T-48	Valve Bar	65	AM-CL-22T-65	Wing Net
49	AM-CL-22T-49	Under Metal	66	AM-CL-22T-66	Brass Cup

PART LIST OF AMCL-22T HTP POWER SPRAYER

SL NO	PART NO	DESCRIPTION	SL NO	PART NO	DESCRIPTION
67	AM-CL-22T-67	Overflow Hose	83	AM-CL-22T-83	Valve Spring
68	AM-CL-22T-68	Overflow Hose Assy	84	AM-CL-22T-84	Spring Box
69	AM-CL-22T-69	O-Ring			
70	AM-CL-22T-70	Core Coupling			
71	AM-CL-22T-71	Brass Cup			
72	AM-CL-22T-72	Suction Hose			
73	AM-CL-22T-73	Core Strainer			
74	AM-CL-22T-74	Strainer Assy			
75	AM-CL-22T-75	Suction Hose Assy			
76	AM-CL-22T-76	Cylinder Assy			
77	AM-CL-22T-77	Adjusting Belt			
78	AM-CL-22T-78	Plunger Cover			
79	AM-CL-22T-79	Key			
80	AM-CL-22T-80	Valve Seal			
81	AM-CL-22T-81	Valve Seat			
82	AM-CL-22T-82	Stopper			



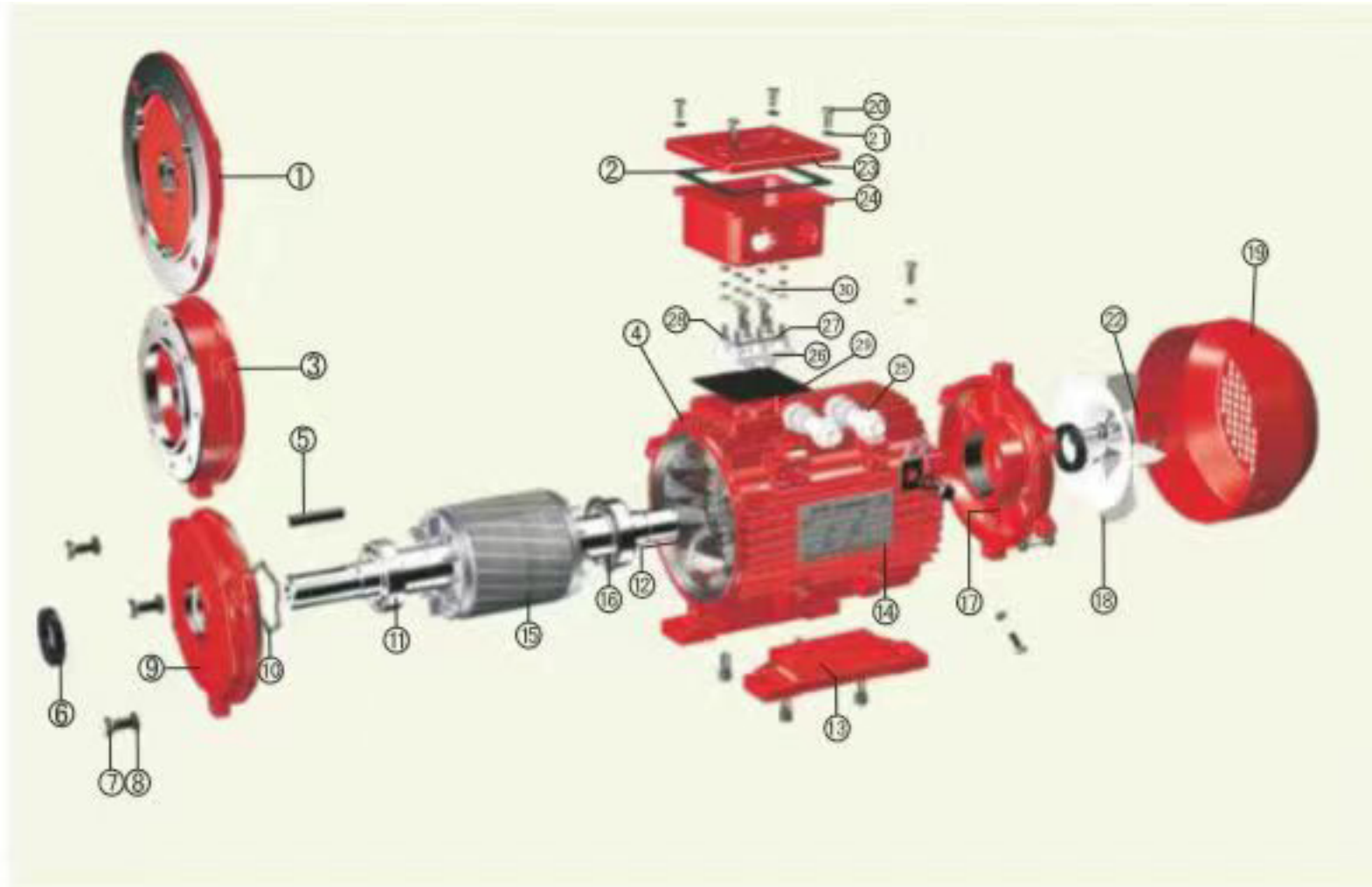

MOTOR DIAGRAM & PART LIST



SL NO	PART NO	DESCRIPTION	SL NO	PART NO	DESCRIPTION
1	AM-3HPM-01	Flange	17	AM-3HPM-17	Rear end sheild
2	AM-3HPM-02	Gasket	18	AM-3HPM-18	Fan
3	AM-3HPM-03	Flange	19	AM-3HPM-19	Fan Cowl
4	AM-3HPM-04	Frame	20	AM-3HPM-20	Screw
5	AM-3HPM-05	Key	21	AM-3HPM-21	Washer
6	AM-3HPM-06	Oil Seal	22	AM-3HPM-22	Fan Clamp
7	AM-3HPM-07	Bolt	23	AM-3HPM-23	Terminal box lid
8	AM-3HPM-08	Spring washer	24	AM-3HPM-24	Terminal box bases
9	AM-3HPM-09	Front end sheild	25	AM-3HPM-25	Cable gland
10	AM-3HPM-10	Wave Washer	26	AM-3HPM-26	Terminal board
11	AM-3HPM-11	Bearing	27	AM-3HPM-27	Brass lug
12	AM-3HPM-12	Stator	28	AM-3HPM-28	Brass nut
13	AM-3HPM-13	Feet	29	AM-3HPM-29	Earth mark
14	AM-3HPM-14	NA	30	AM-3HPM-30	Brass washer
15	AM-3HPM-15	Rotor			
16	AM-3HPM-16	Circlip			





WARRANTY CARD

CUSTOMER COPY

DATE _____	DATE OF DELIVERY _____	DEALERS OFFICIAL SEAL	DEALERS SIGN _____
PURCHASERS NAME & ADDRESS _____ _____	 CUSTOMER SIGN		
PRODUCT NAME	PRODUCT SERIAL NO.	INVOICE/DN NO.	
			





I/Will accept the terms and conditions of warranty as in the warranty card

DEALERS COPY

DATE _____	DATE OF DELIVERY _____	DEALERS OFFICIAL SEAL	DEALERS SIGN _____
PURCHASERS NAME & ADDRESS _____ _____	 CUSTOMER SIGN		
PRODUCT NAME	PRODUCT SERIAL NO.	INVOICE/DN NO.	
			

I/Will accept the terms and conditions of warranty as in the warranty card

COMPANY COPY

DATE _____	DATE OF DELIVERY _____	DEALERS OFFICIAL SEAL	DEALERS SIGN _____
PURCHASERS NAME & ADDRESS _____ _____	 CUSTOMER SIGN		
PRODUCT NAME	PRODUCT SERIAL NO.	INVOICE/DN NO.	
			

I/Will accept the terms and conditions of warranty as in the warranty card

1. LIMITED WARRANTY PERIOD : For a period of six months from the date of Sale / delivery of the product which ever is earlier. 2. LIMITED WARRANTY OBLIGATION : Replacement of defective part(s) by authorized dealer are free of charges. If found defective by reasons of defective material / poor workmanship, parts will be replaced and there will be no value re-imburement. 3. TERMS & CONDITIONS : a. Claims under warranty will be accepted on submission of Warranty Card duly filled and stamped by authorized dealer together with the original purchase document. : b. Shipping / transportation / Incidental charges incurred in replacing defective parts under warranty shall be borne by the purchaser

WARRANTY null & void if

- (i) Lack of maintenance, (ii) Incorrect use of the machine or tampering, (iii) Use of non-genuine spare parts, (iv) Usage of acids, solvents, or any flammable materials, (v) Non-usage of filter water / clear water / soft water & using water above 40°C temperature, (vi) While using the pressure washers to draw water which is contaminated with dust & solvents (eg. paint thinners, gasoline, oil, etc.), (vii) Repair done by unauthorized service people, (viii) Those parts subject to wear & tear due to normal operations and plastic parts, rubber items etc, (ix) Loose connections, faulty electrical fixtures & fluctuations in power supply.
- 4. Should any failure occur during or after the warranty period, customer does not have the right to interrupt payment / price discount.
- 5. Incidental or consequential damages like inconvenience commercial loss, loss of tie, mental agony etc.
- 6. Loss of any nature due to operation or non-operation is not covered under warranty.
- 7. All free service are at Dealer's service point only.
- 8. Warranty ceases if service is not done periodically.
- 9. The attached card should be completed and returned to Ratnagiri Impex Pvt. Ltd. for registration immediately after sale / delivery.
- 10. The warranty is void unless you register the warranty card with Ratnagiri Impex Pvt. Ltd.
- 11. The decision of Ratnagiri Impex Pvt. Ltd., in settling the warranty is final in all respects.
- 12. All disputes are subject to Bangalore Courts Jurisdiction

1. LIMITED WARRANTY PERIOD : For a period of six months from the date of Sale / delivery of the product which ever is earlier. 2. LIMITED WARRANTY OBLIGATION : Replacement of defective part(s) by authorized dealer are free of charges. If found defective by reasons of defective material / poor workmanship, parts will be replaced and there will be no value re-imburement. 3. TERMS & CONDITIONS : a. Claims under warranty will be accepted on submission of Warranty Card duly filled and stamped by authorized dealer together with the original purchase document. : b. Shipping / transportation / Incidental charges incurred in replacing defective parts under warranty shall be borne by the purchaser.

WARRANTY null & void if

- (i) Lack of maintenance, (ii) Incorrect use of the machine or tampering, (iii) Use of non-genuine spare parts, (iv) Usage of acids, solvents, or any flammable materials, (v) Non-usage of filter water / clear water / soft water & using water above 40°C temperature, (vi) While using the pressure washers to draw water which is contaminated with dust & solvents (eg. paint thinners, gasoline, oil, etc.), (vii) Repair done by unauthorized service people, (viii) Those parts subject to wear & tear due to normal operations and plastic parts, rubber items etc, (ix) Loose connections, faulty electrical fixtures & fluctuations in power supply.
- 4. Should any failure occur during or after the warranty period, customer does not have the right to interrupt payment / price discount.
- 5. Incidental or consequential damages like inconvenience commercial loss, loss of tie, mental agony etc.
- 6. Loss of any nature due to operation or non-operation is not covered under warranty.
- 7. All free service are at Dealer's service point only.
- 8. Warranty ceases if service is not done periodically.
- 9. The attached card should be completed and returned to Ratnagiri Impex Pvt. Ltd. for registration immediately after sale / delivery.
- 10. The warranty is void unless you register the warranty card with Ratnagiri Impex Pvt. Ltd.
- 11. The decision of Ratnagiri Impex Pvt. Ltd., in settling the warranty is final in all respects.
- 12. All disputes are subject to Bangalore Courts Jurisdiction

1. LIMITED WARRANTY PERIOD : For a period of six months from the date of Sale / delivery of the product which ever is earlier. 2. LIMITED WARRANTY OBLIGATION : Replacement of defective part(s) by authorized dealer are free of charges. If found defective by reasons of defective material / poor workmanship, parts will be replaced and there will be no value re-imburement. 3. TERMS & CONDITIONS : a. Claims under warranty will be accepted on submission of Warranty Card duly filled and stamped by authorized dealer together with the original purchase document. : b. Shipping / transportation / Incidental charges incurred in replacing defective parts under warranty shall be borne by the purchaser.

WARRANTY null & void if

- (i) Lack of maintenance, (ii) Incorrect use of the machine or tampering, (iii) Use of non-genuine spare parts, (iv) Usage of acids, solvents, or any flammable materials, (v) Non-usage of filter water / clear water / soft water & using water above 40°C temperature, (vi) While using the pressure washers to draw water which is contaminated with dust & solvents (eg. paint thinners, gasoline, oil, etc.), (vii) Repair done by unauthorized service people, (viii) Those parts subject to wear & tear due to normal operations and plastic parts, rubber items etc, (ix) Loose connections, faulty electrical fixtures & fluctuations in power supply.
- 4. Should any failure occur during or after the warranty period, customer does not have the right to interrupt payment / price discount.
- 5. Incidental or consequential damages like inconvenience commercial loss, loss of tie, mental agony etc.
- 6. Loss of any nature due to operation or non-operation is not covered under warranty.
- 7. All free service are at Dealer's service point only.
- 8. Warranty ceases if service is not done periodically.
- 9. The attached card should be completed and returned to Ratnagiri Impex Pvt. Ltd. for registration immediately after sale / delivery.
- 10. The warranty is void unless you register the warranty card with Ratnagiri Impex Pvt. Ltd.
- 11. The decision of Ratnagiri Impex Pvt. Ltd., in settling the warranty is final in all respects.
- 12. All disputes are subject to Bangalore Courts Jurisdiction



FREE SERVICE COUPON (30DAYS/30HRS. WHICHEVER IS EARLIER)

MODEL

SERIAL NUMBER

PDI DATE

SERVICE NO.

PURCHASE BILL NO.

DATE

DEALERS OFFICE SEAL

- 1. Check and test the fuel mixture
- 3. Check , clean and adjust the spark plug
- 5. Check and sparken the cutting tools
- 7. Start and check the noise, vibration, loosen etc..

OPERATIONS

- 2. check and clean the air filter
- 4. Check and adjust the carburetor tuning
- 6. Product familirisation on usage
- 8. Routine maintenance and shortage.

FREE SERVICE COUPON (30DAYS/30HRS. WHICHEVER IS EARLIER)

MODEL

SERIAL NUMBER

PDI DATE

SERVICE NO.

PURCHASE BILL NO.

DATE

DEALERS OFFICE SEAL

- 1. Check and test the fuel mixture
- 3. Check , clean and adjust the spark plug
- 5. Check and sparken the cutting tools
- 7. Start and check the noise, vibration, loosen etc..

OPERATIONS

- 2. check and clean the air filter
- 4. Check and adjust the carburetor tuning
- 6. Product familirisation on usage
- 8. Routine maintenance and shortage.

FREE SERVICE COUPON (30DAYS/30HRS. WHICHEVER IS EARLIER)

MODEL

SERIAL NUMBER

PDI DATE

SERVICE NO.

PURCHASE BILL NO.

DATE

DEALERS OFFICE SEAL

- 1. Check and test the fuel mixture
- 3. Check , clean and adjust the spark plug
- 5. Check and sparken the cutting tools
- 7. Start and check the noise, vibration, loosen etc..

OPERATIONS

- 2. check and clean the air filter
- 4. Check and adjust the carburetor tuning
- 6. Product familirisation on usage
- 8. Routine maintenance and shortage.

DOS

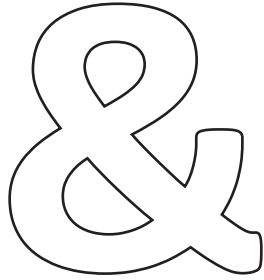

DONT'S

1. Always read the instruction manual supplied along with the equipments and understand the correct installation and operating procedures before attempting to use the equipments.
2. It is important to use the personal protection equipments such as head helmet with visor, ear defenders, goggles, safety gloves, cut resistant shoes, trousers and jackets while operating potentially dangerous machines
3. Avoid untrained persons using the equipments. Children must not be allowed to handle these equipments
4. Always use genuine spares and accessories in repairs and usage to derive maximum life of the equipments.
5. Always keep the equipments in good working condition to minimize loss of output as well as to reduce the pollution and save the environment
6. Do not use the machine within range of persons unless they wear protective clothing
7. Do not operate the machine when fatigued or under the influence of alcohol or drugs
8. When the machine is running, please maintain a constant water supply. Without water circulation will damage the sealing rings of the machine.
9. For more query kindly contact for our Service Center/Dealer/ franchise

Agrimate Army For Pest Control

ANY WHERE - ANY TIME - ANY CROP

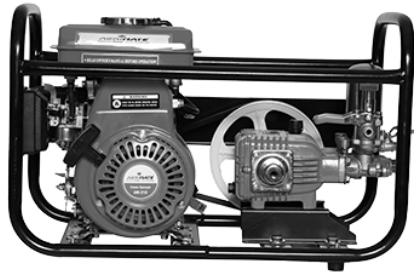
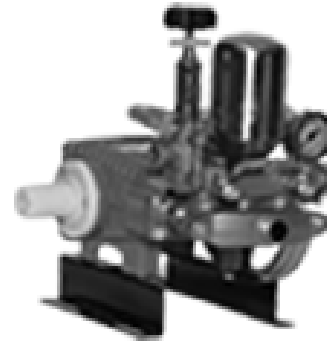

Marketed by:
**ratnagiri
impex**
BRINGING YOU THE FUTURE... NOW

RATNAGIRI IMPEX PVT., LTD.,

Annapurna House, #1 / 1G, 7th Cross, New
Guddadahalli

Mysore Road, Bangalore - 560 026

Missed Call : 7393 938 938

Email: ask@agrimart.in