

INTERCULTIVATOR/POWER WEEDER

AM-2620-DGB-9DE
TRANSMISSION PARTS LIST

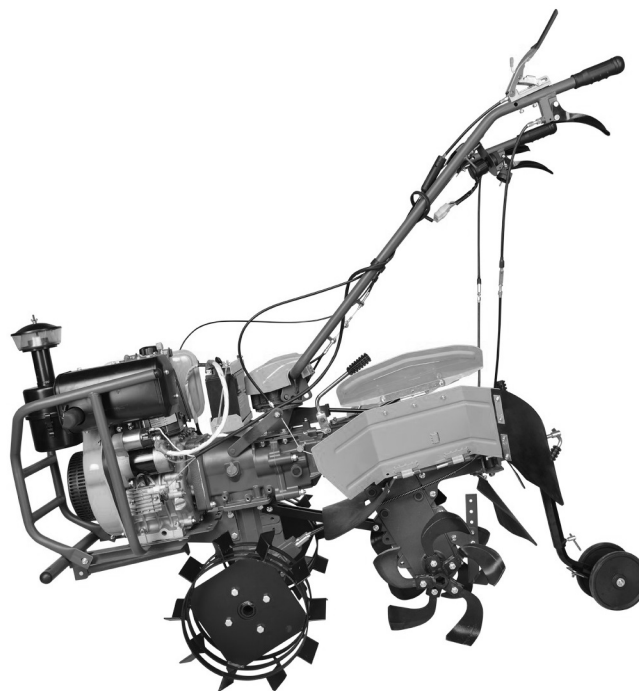

SPARE PARTS DIAGRAM & PART LIST OF AM-2620-DGB-9D/6D TRANSMISSION

TRANSMISSION CASE COMPONENT - A

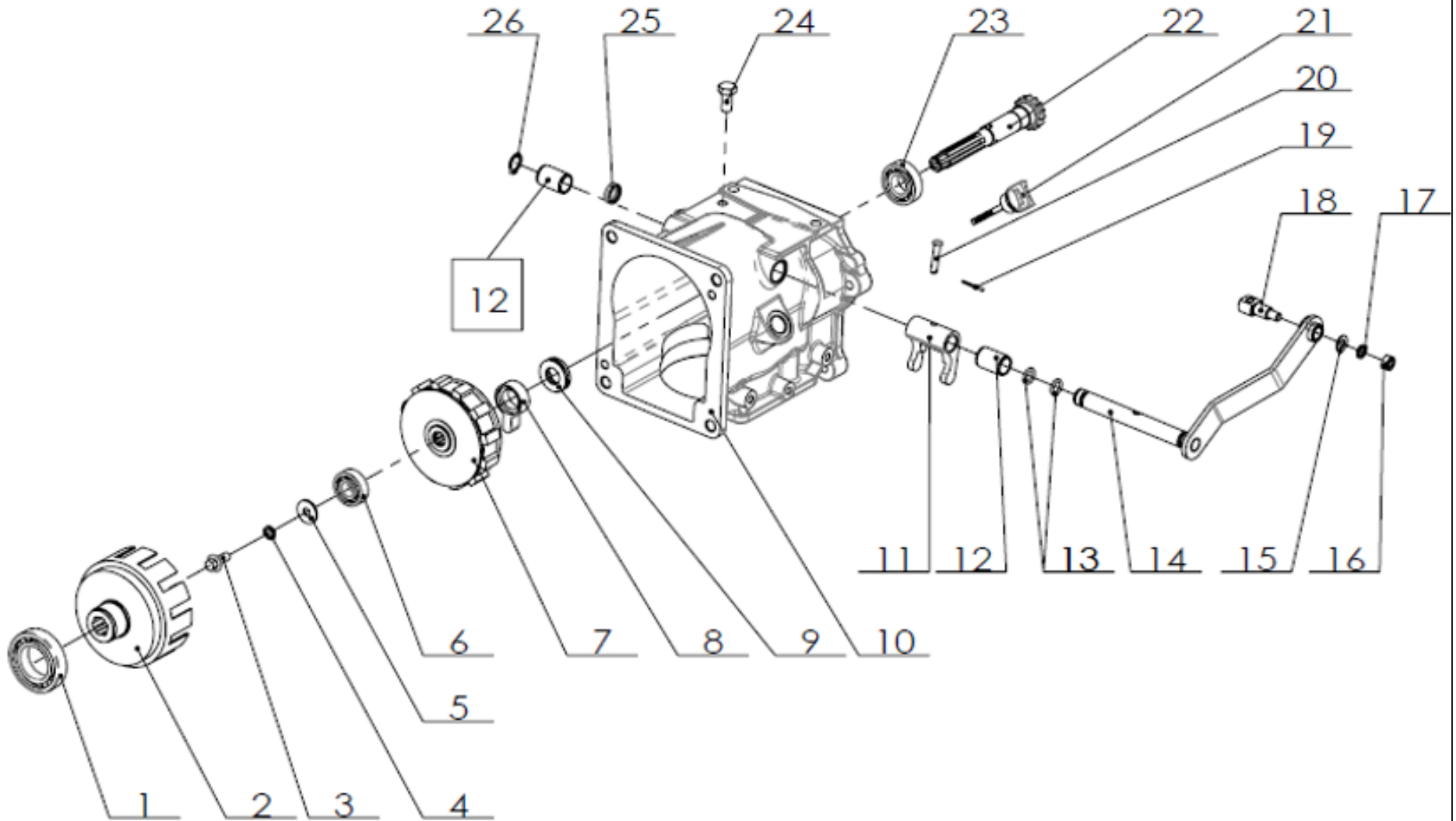

SPARE PARTS DIAGRAM & PART LIST OF AM-2620-DGB-9D/6D TRANSMISSION

SL NO	PART NO	DESCRIPTION	SL NO	PART NO	DESCRIPTION
1	AM-2620-DGB-A01	Deep groove ball bearings	15	AM-2620-DGB-A15	Flat washer
2	AM-2620-DGB-A02	Clutch cover assembly	16	AM-2620-DGB-A16	Hex nut
3	AM-2620-DGB-A03	Hexagon flange bolt small series	17	AM-2620-DGB-A17	Spring washer
4	AM-2620-DGB-A04	External serrated lock washer	18	AM-2620-DGB-A18	Clutch cable movable seat
5	AM-2620-DGB-A05	Large washers	19	AM-2620-DGB-A19	Split pin
6	AM-2620-DGB-A06	Bearing	20	AM-2620-DGB-A20	Pin
7	AM-2620-DGB-A07	Clutch core assembly	21	AM-2620-DGB-A21	Dipstick assembly
8	AM-2620-DGB-A08	T26 friction disc	22	AM-2620-DGB-A22	Spindle
9	AM-2620-DGB-A09	Cushion Cover	23	AM-2620-DGB-A23	Deep groove ball bearings
10	AM-2620-DGB-A10	Gear box	24	AM-2620-DGB-A24	Hexagon head bolt
11	AM-2620-DGB-A11	Clutch fork	25	AM-2620-DGB-A25	Oil plug
12	AM-2620-DGB-A12	Bushing	26	AM-2620-DGB-A26	Circlip for shaft
13	AM-2620-DGB-A13	O-ring			
14	AM-2620-DGB-A14	Clutch fork shaft			

SPARE PARTS DIAGRAM & PART LIST OF AM-2620-DGB-9D/6D TRANSMISSION

TRANSMISSION BACK CASE COMP-B

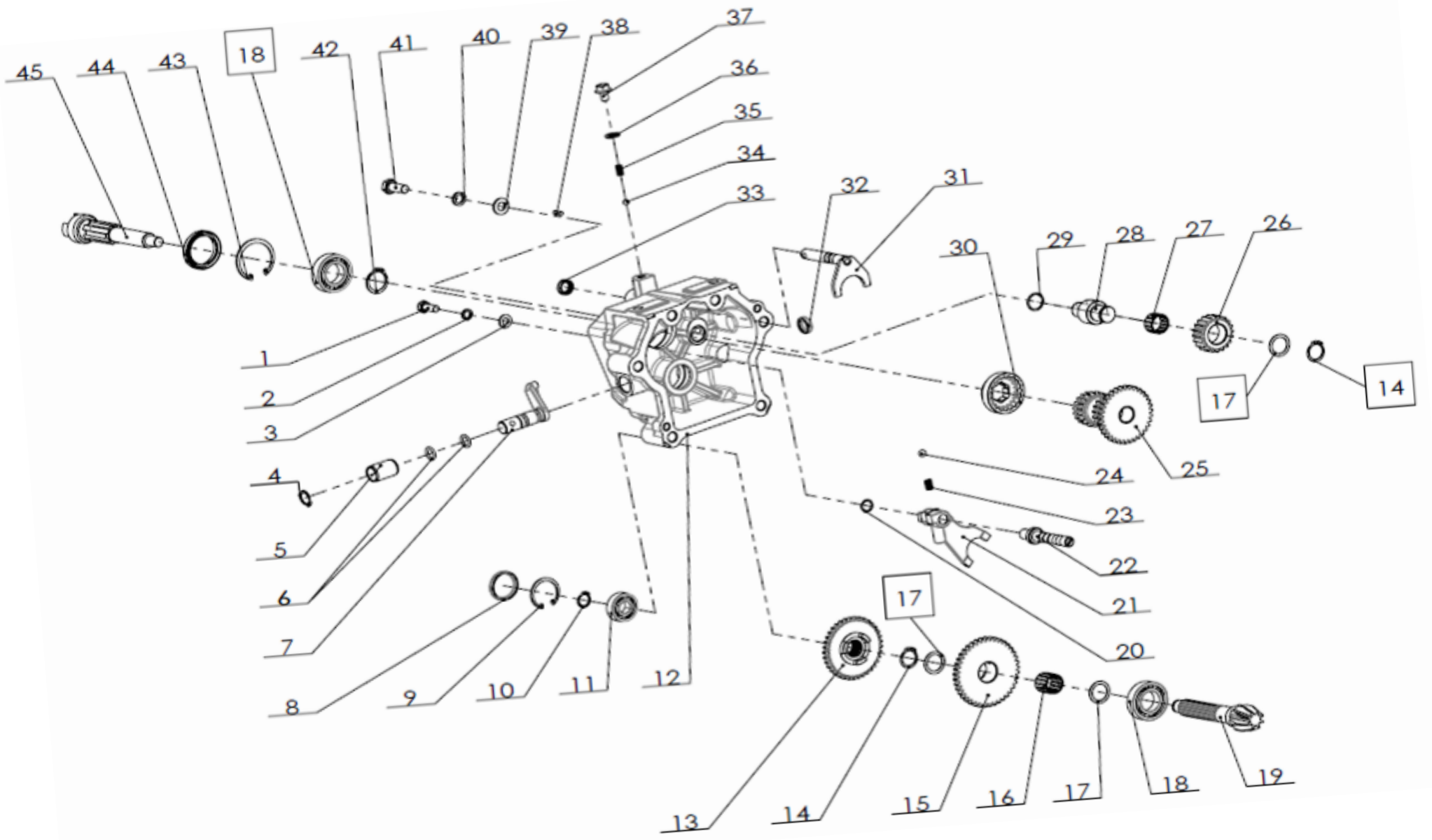

SPARE PARTS DIAGRAM & PART LIST OF AM-2620-DGB-9D/6D TRANSMISSION

SL NO	PART NO	DESCRIPTION	SL NO	PART NO	DESCRIPTION
1	AM-2620-DGB-B01	Hexagon head bolt	16	AM-2620-DGB-B16	Needle bearing
2	AM-2620-DGB-B02	Spring washer	17	AM-2620-DGB-B17	Adjusting washer
3	AM-2620-DGB-B03	Flat washer	18	AM-2620-DGB-B18	Deep groove ball bearings
4	AM-2620-DGB-B04	Circlip for shaft	19	AM-2620-DGB-B19	Countershaft
5	AM-2620-DGB-B05	Bushing	20	AM-2620-DGB-B20	O-ring
6	AM-2620-DGB-B06	O-ring	21	AM-2620-DGB-B21	Shift fork
7	AM-2620-DGB-B07	Shift rocker arm	22	AM-2620-DGB-B22	Shift fork shaft
8	AM-2620-DGB-B08	Oil plug	23	AM-2620-DGB-B23	Shift spring
9	AM-2620-DGB-B09	Circlip for hole	24	AM-2620-DGB-B24	Steel ball
10	AM-2620-DGB-B10	Circlip for shaft	25	AM-2620-DGB-B25	Triple gear
11	AM-2620-DGB-B11	Deep groove ball bearings	26	AM-2620-DGB-B26	Reverse gear
12	AM-2620-DGB-B12	Gearbox rear cover	27	AM-2620-DGB-B27	Needle roller bearing
13	AM-2620-DGB-B13	Shift gear A	28	AM-2620-DGB-B28	Reverse gear shaft
14	AM-2620-DGB-B14	Circlip for shaft	29	AM-2620-DGB-B29	O-ring
15	AM-2620-DGB-B15	Transmission double gear	30	AM-2620-DGB-B30	PTO dial

SPARE PARTS DIAGRAM & PART LIST OF AM-2620-DGB-9D/6D TRANSMISSION

SL NO	PART NO	DESCRIPTION	SL NO	PART NO	DESCRIPTION
31	AM-2620-DGB-B31	PTO fork shaft assembly			
32	AM-2620-DGB-B32	Oil plug			
33	AM-2620-DGB-B33	Oil seal			
34	AM-2620-DGB-B34	Steel ball			
35	AM-2620-DGB-B35	Compression spring			
36	AM-2620-DGB-B36	Sealing gasket			
37	AM-2620-DGB-B37	Hexagon flange bolt small series			
38	AM-2620-DGB-B38	Cylindrical pin unhardened steel and austenitic stainless steel			
39	AM-2620-DGB-B39	Flat washer			
40	AM-2620-DGB-B40	Spring washer			
41	AM-2620-DGB-B41	Hexagon flange bolt			
42	AM-2620-DGB-B42	Circlip for shaft			
43	AM-2620-DGB-B43	Circlips for holes			
44	AM-2620-DGB-B44	Oil seal			
45	AM-2620-DGB-B45	PTO output shaft			

SPARE PARTS DIAGRAM & PART LIST OF AM-2620-DGB-9D/6D TRANSMISSION

TRANSMISSION COMBINATION PARTS -C

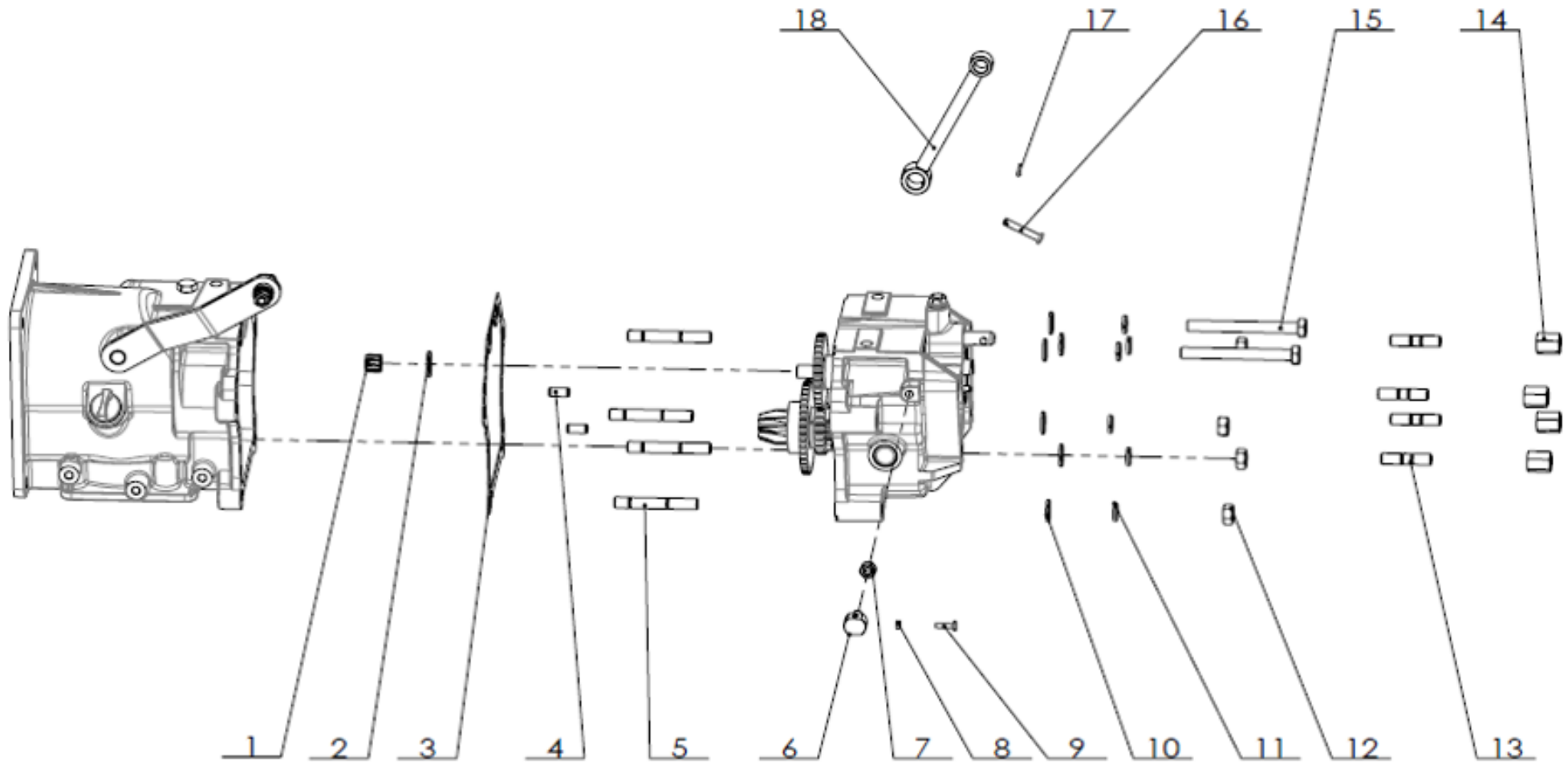

SPARE PARTS DIAGRAM & PART LIST OF AM-2620-DGB-9D/6D TRANSMISSION

SL NO	PART NO	DESCRIPTION	SL NO	PART NO	DESCRIPTION
1	AM-2620-DGB-C01	Needle bearing			
2	AM-2620-DGB-C02	Wear-resistant washer			
3	AM-2620-DGB-C03	Shift rear box paper pad			
4	AM-2620-DGB-C04	Locating pin			
5	AM-2620-DGB-C05	Double-ended stud			
6	AM-2620-DGB-C06	Clutch seat			
7	AM-2620-DGB-C07	Hexagon Thin Nut			
8	AM-2620-DGB-C08	Type 1 hexagon nut			
9	AM-2620-DGB-C09	Full Thread Hexagon Head Bolt			
10	AM-2620-DGB-C10	Flat washer			
11	AM-2620-DGB-C11	Spring washer			
12	AM-2620-DGB-C12	Type 1 hexagon nut			
13	AM-2620-DGB-C13	Isometric double-ended stud C grade			
14	AM-2620-DGB-C14	Cylinder head nut			
15	AM-2620-DGB-C15	Hexagon head bolt			
16	AM-2620-DGB-C16	Pin			
17	AM-2620-DGB-C17	Circlip A			
18	AM-2620-DGB-C18	Gear shift connecting arm			

SPARE PARTS DIAGRAM & PART LIST OF AM-2620-DGB-9D/6D TRANSMISSION

TURN TO TRAVEL BOX ASSY- D

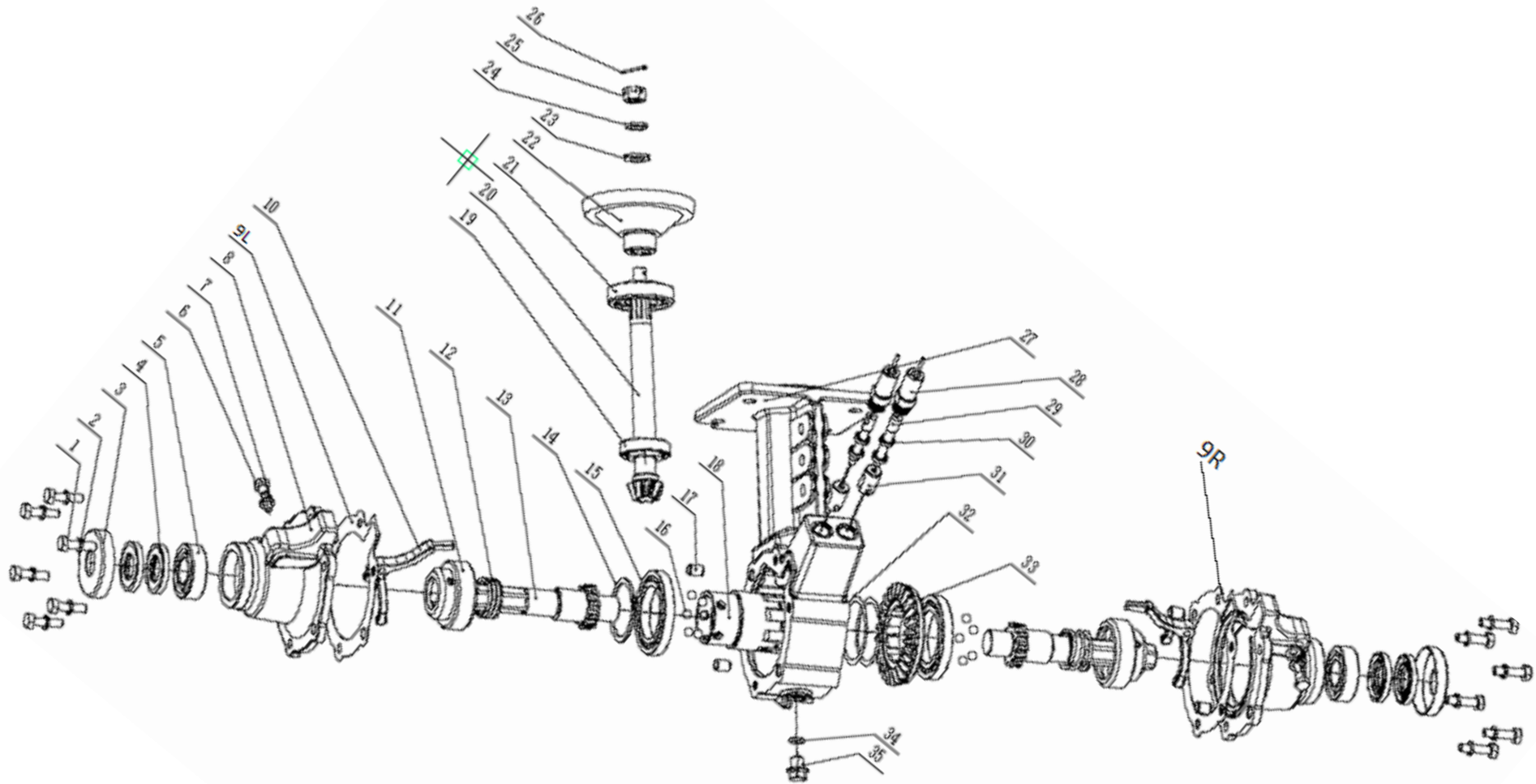

SPARE PARTS DIAGRAM & PART LIST OF AM-2620-DGB-9D/6D TRANSMISSION

SL NO	PART NO	DESCRIPTION	SL NO	PART NO	DESCRIPTION
1	AM-2620-DGB-D01	Hexagon head bolts full thread	18	AM-2620-DGB-D18	Spline bushing
2	AM-2620-DGB-D02	Standard spring washer	19	AM-2620-DGB-D19	Tapered Roller Bearings
3	AM-2620-DGB-D03	Dust cover	20	AM-2620-DGB-D20	Bevel gear shaft
4	AM-2620-DGB-D04	Oil seal	21	AM-2620-DGB-D21	Tapered Roller Bearings
5	AM-2620-DGB-D05	Deep groove ball bearing	22	AM-2620-DGB-D22	Driven bevel gear
6	AM-2620-DGB-D06	Lock bolt	23	AM-2620-DGB-D23	Flat washer A grade
7	AM-2620-DGB-D07	Non-standard flat washers	24	AM-2620-DGB-D24	Standard spring washer
8	AM-2620-DGB-D08	Travel box end cover	25	AM-2620-DGB-D25	Hexagon Slotted Thin Nuts Class A and B
9L	AM-2620-DGB-D09L	End cover paper pad Left	26	AM-2620-DGB-D26	Split pin
9R	AM-2620-DGB-D09R	End cover paper pad Right	27	AM-2620-DGB-D27	Walking box
10	AM-2620-DGB-D10	Steering separation fork	28	AM-2620-DGB-D28	Steering cable
11	AM-2620-DGB-D11	Steering wheel	29	AM-2620-DGB-D29	Connector
12	AM-2620-DGB-D12	Steering clutch return compression spring	30	AM-2620-DGB-D30	Oil seal
13	AM-2620-DGB-D13	Half shaft	31	AM-2620-DGB-D31	Cable seat
14	AM-2620-DGB-D14	Circlip for shaft	32	AM-2620-DGB-D32	Non-standard flat washer
15	AM-2620-DGB-D15	Deep groove ball bearing	33	AM-2620-DGB-D33	Walking bevel gear
16	AM-2620-DGB-D16	Steel ball	34	AM-2620-DGB-D34	O-shaped rubber sealing ring
17	AM-2620-DGB-D17	Positioning pin	35	AM-2620-DGB-D35	Oil drain bolt

SPARE PARTS DIAGRAM & PART LIST OF AM-2620-DGB-9D/6D TRANSMISSION

ENGINE CONNECTIONS -E

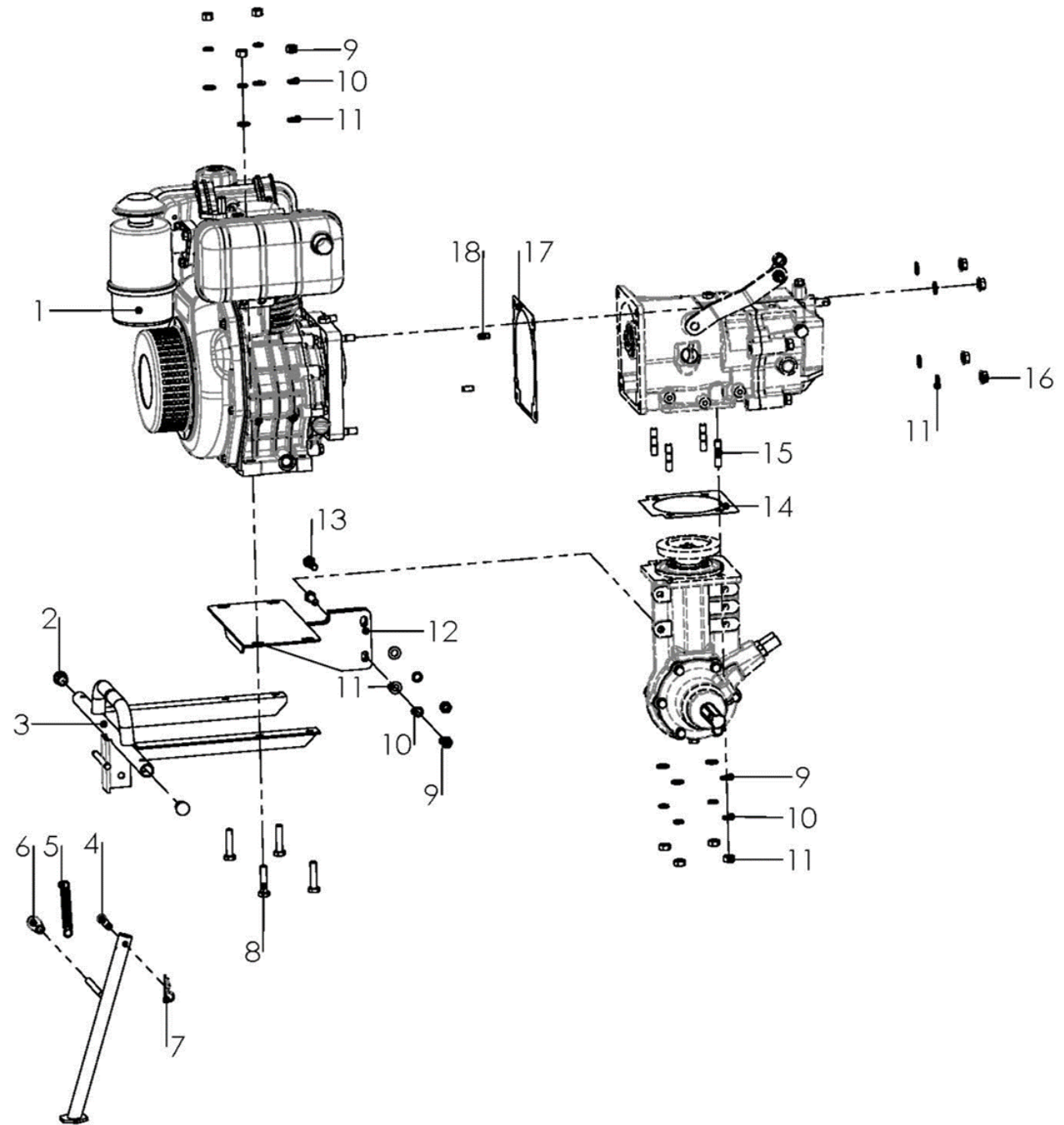

SPARE PARTS DIAGRAM & PART LIST OF AM-2620-DGB-9D/6D TRANSMISSION

SL NO	PART NO	DESCRIPTION	SL NO	PART NO	DESCRIPTION
1	AM-2620-DGB-E01	AM-186F engine			
2	AM-2620-DGB-E02	Bumper plug			
3	AM-2620-DGB-E03	Lower bumper			
	AM-2620-DGB-E3.1	Upper bumper			
4	AM-2620-DGB-E04	Pin shaft			
5	AM-2620-DGB-E05	Support leg extension spring			
6	AM-2620-DGB-E06	Small crank rubber sleeve			
7	AM-2620-DGB-E07	Circlip_B			
8	AM-2620-DGB-E08	Hexagon head bolts full thread			
9	AM-2620-DGB-E09	Hex nut			
10	AM-2620-DGB-E10	Spring washer			
11	AM-2620-DGB-E11	Flat washer			
12	AM-2620-DGB-E12	Engine bracket			
	AM-2620-DGB-E12.1	Engine bracket			
13	AM-2620-DGB-E13	Hexagon head bolts full thread			
14	AM-2620-DGB-E14	Packing paper pad			
15	AM-2620-DGB-E15	Isometric double-ended stud C grade			
16	AM-2620-DGB-E16	Type 2 hexagon flange nut			
17	AM-2620-DGB-E17	Flange and gearbox paper gasket			
18	AM-2620-DGB-E18	Locating pin			

SPARE PARTS DIAGRAM & PART LIST OF AM-2620-DGB-9D/6D TRANSMISSION

HAND STAND PARTS -G

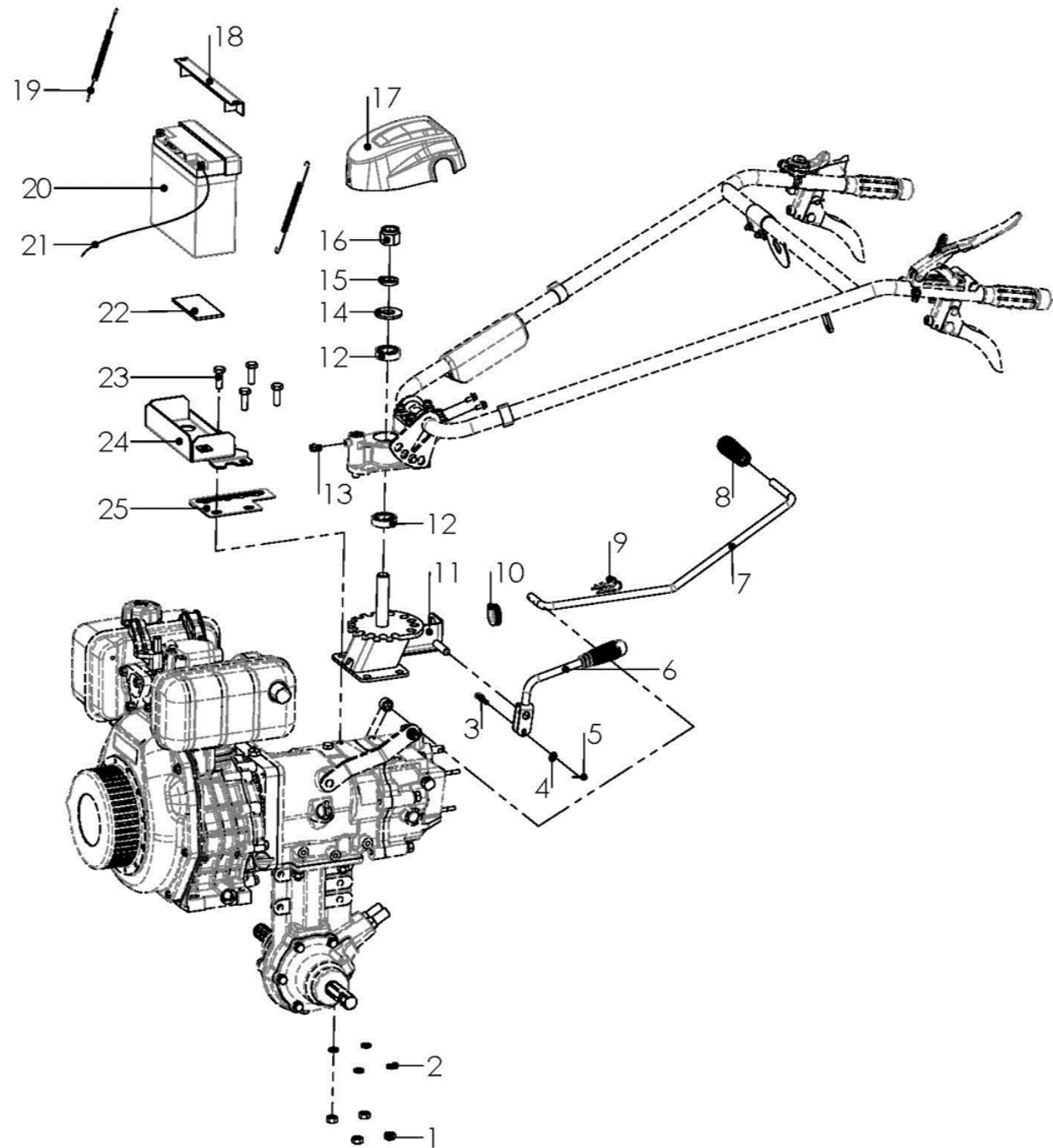

SPARE PARTS DIAGRAM & PART LIST OF AM-2620-DGB-9D/6D TRANSMISSION

SL NO	PART NPO	DESCRIPTION	SL NO	PART NO	DESCRIPTION
1	AM-2620-DGB-G01	Type 1 Hexagon Nut	14	AM-2620-DGB-G14	Gasket
2	AM-2620-DGB-G02	Standard spring washer	15	AM-2620-DGB-G15	Standard spring washer
3	AM-2620-DGB-G03	Pin	16	AM-2620-DGB-G16	Hexagon lock nuts with non-metallic insert
4	AM-2620-DGB-G04	Flat washer	17	AM-2620-DGB-G17	Armrest seat cover
5	AM-2620-DGB-G05	Split pin	18	AM-2620-DGB-G18	Battery layering
6	AM-2620-DGB-G06	PTO joystick B	19	AM-2620-DGB-G19	Speed control spring
7	AM-2620-DGB-G07	Shift lever	20	AM-2620-DGB-G20	Battery
8	AM-2620-DGB-G08	shock-absorbing grip	21	AM-2620-DGB-G21	Battery connection line
9	AM-2620-DGB-G09	Circlip_B	22	AM-2620-DGB-G22	Anti-vibration rubber pad
10	AM-2620-DGB-G10	Armrest seat wear-resistant cover	23	AM-2620-DGB-G23	Hexagon Flange Bolt Small Series
11	AM-2620-DGB-G11	Armrest seat_A	24	AM-2620-DGB-G24	Battery box
12	AM-2620-DGB-G12	Deep groove ball bearing	25	AM-2620-DGB-G25	Gear indicator
13	AM-2620-DGB-G13	Hexagon flange bolts, enlarged series, grade B,			

SPARE PARTS DIAGRAM & PART LIST OF AM-2620-DGB-9D/6D TRANSMISSION

HANDLE STAND WITH PARTS-GA

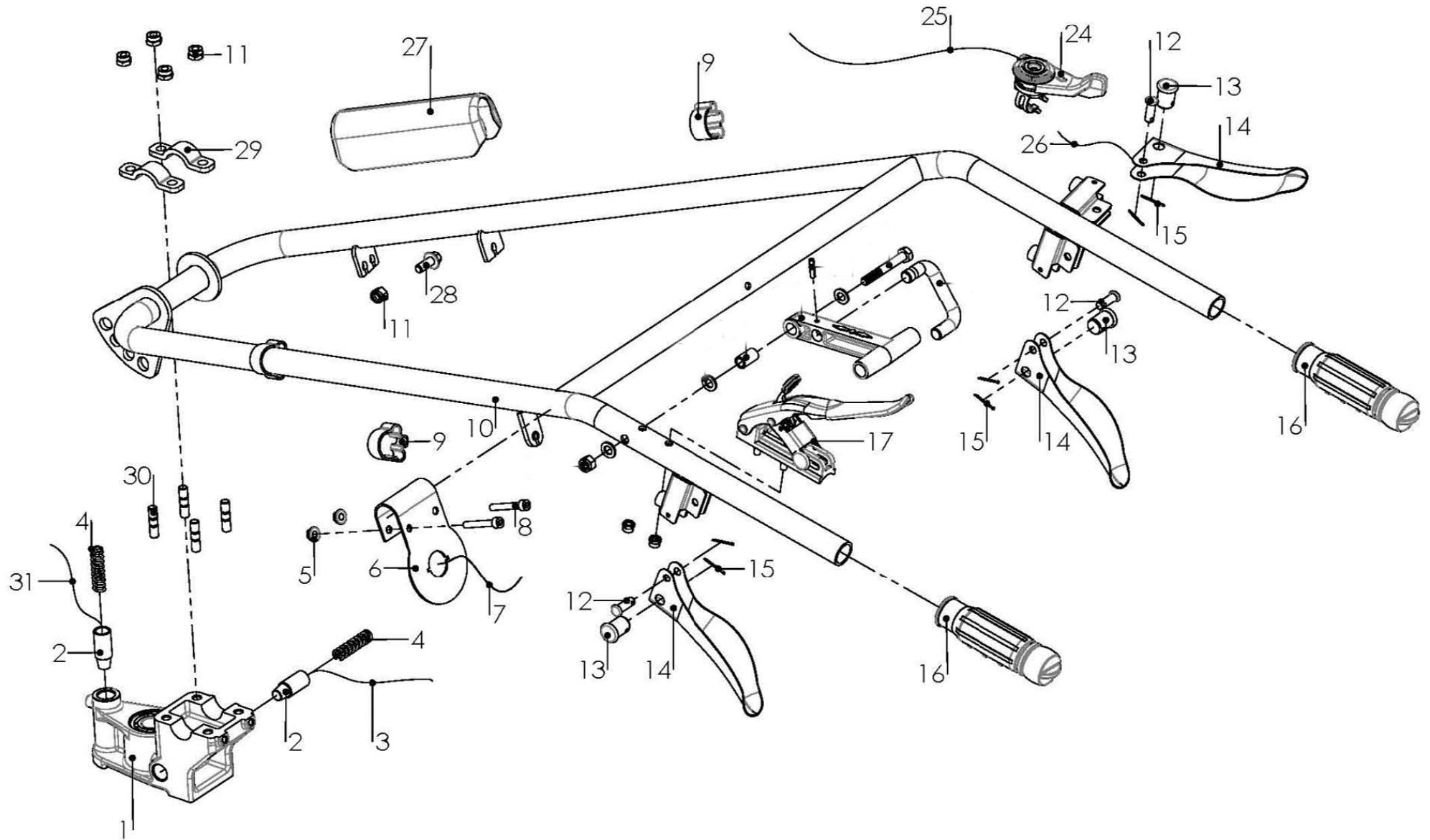

SPARE PARTS DIAGRAM & PART LIST OF AM-2620-DGB-9D/6D TRANSMISSION

SL NO	PART NO	DESCRIPTION	SL NO	PART NO	DESCRIPTION
1	AM-2620-DGB-GA01	Rotating seat	17	AM-2620-DGB-GA17	Clutch handle assembly
2	AM-2620-DGB-GA02	Steering pin	18	AM-2620-DGB-GA18	NA
3	AM-2620-DGB-GA03	Armrest height adjustment cable	19	AM-2620-DGB-GA19	NA
4	AM-2620-DGB-GA04	Regulating pressure spring	20	AM-2620-DGB-GA20	NA
5	AM-2620-DGB-GA05	Type 2 Hexagon Flange Nut	21	AM-2620-DGB-GA21	NA
6	AM-2620-DGB-GA06	electric start positioning block	22	AM-2620-DGB-GA22	NA
7	AM-2620-DGB-GA07	Electric start control wiring harness	23	AM-2620-DGB-GA23	NA
8	AM-2620-DGB-GA08	Hexagon socket head screw	24	AM-2620-DGB-GA24	throttle switch
9	AM-2620-DGB-GA09	Self-locking hoop	25	AM-2620-DGB-GA25	Throttle cable
10	AM-2620-DGB-GA10	Armrest	26	AM-2620-DGB-GA26	Adjust the main cable
11	AM-2620-DGB-GA11	NA	27	AM-2620-DGB-GA27	Armrest side cover
12	AM-2620-DGB-GA12	Non-standard pin shaft	28	AM-2620-DGB-GA28	Hexagon flange bolt small series
13	AM-2620-DGB-GA13	Non-standard pin shaft_	29	AM-2620-DGB-GA29	Armrest press block
14	AM-2620-DGB-GA14	Reverse gear clutch handle	30	AM-2620-DGB-GA30	Double-headed stud
15	AM-2620-DGB-GA15	Split pin	31	AM-2620-DGB-GA31	The armrest adjusts the cable left and right
16	AM-2620-DGB-GA16	Damping grip			

SPARE PARTS DIAGRAM & PART LIST OF AM-2620-DGB-9D/6D TRANSMISSION

DITCHING BOX PARTS -H

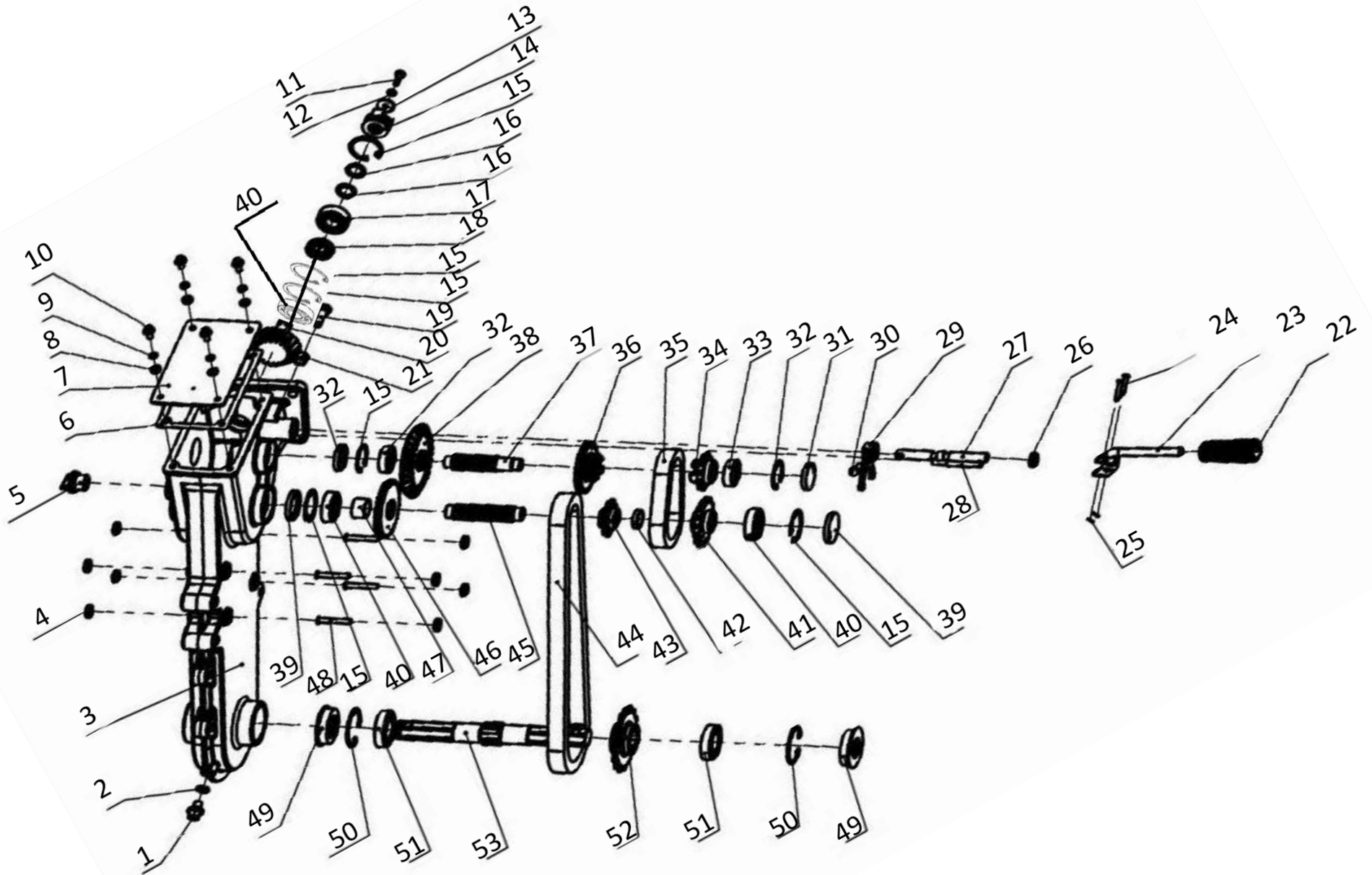

SPARE PARTS DIAGRAM & PART LIST OF AM-2620-DGB-9D/6D TRANSMISSION

SL NO	PART NO	DESCRIPTION	SL NO	PART NO.	DESCRIPTION
1	AM-2620-DGB-H01	Hexagon flange bolts fine pitch small series	14	AM-2620-DGB-H14	Output claw
2	AM-2620-DGB-H02	Aluminum gasket	15	AM-2620-DGB-H15	Retaining ring for hole
3	AM-2620-DGB-H03	Transmission case	16	AM-2620-DGB-H16	Non-standard wear-resistant washer
4	AM-2620-DGB-H04	Oil plug B	17	AM-2620-DGB-H17	Deep groove ball bearings
5	AM-2620-DGB-H05	Oil filling plug	18	AM-2620-DGB-H18	Oil seal
6	AM-2620-DGB-H06	Cover rubber pad	19	AM-2620-DGB-H19	Hexagon head bolt
7	AM-2620-DGB-H07	Box cover	20	AM-2620-DGB-H20	Driving bevel gear
8	AM-2620-DGB-H08	Flat Washers	21	AM-2620-DGB-H21	Hex nut
9	AM-2620-DGB-H09	Elastic washer	22	AM-2620-DGB-H22	shock-absorbing grip
10	AM-2620-DGB-H10	Hex Flange Bolt Increased Series B Grade	23	AM-2620-DGB-H23	Shift handle
11	AM-2620-DGB-H11	Hexagon head bolt	24	AM-2620-DGB-H24	Pin
12	AM-2620-DGB-H12	External serrated lock washers	25	AM-2620-DGB-H25	Split pin
13	AM-2620-DGB-H13	Extra large washer C grade	26	AM-2620-DGB-H26	Oil seal

SPARE PARTS DIAGRAM & PART LIST OF AM-2620-DGB-9D/6D TRANSMISSION

SL NO	PART NO	DESCRIPTION	SL NO	PART NO	DESCRIPTION
27	AM-2620-DGB-H27	Fork shaft	40	AM-2620-DGB-H40	Deep groove ball bearings
28	AM-2620-DGB-H28	Shift support arm	41	AM-2620-DGB-H41	Cultivation box driven sprocket
29	AM-2620-DGB-H29	Shift fork	42	AM-2620-DGB-H42	Bushing
30	AM-2620-DGB-H30	Hexagon head bolt	43	AM-2620-DGB-H43	Drive sprocket
31	AM-2620-DGB-H31	Oil plug	44	AM-2620-DGB-H44	Chain
32	AM-2620-DGB-H32	Circlip for hole	45	AM-2620-DGB-H45	Drive shaft
33	AM-2620-DGB-H33	Deep groove ball shaft	46	AM-2620-DGB-H46	Driven gear
34	AM-2620-DGB-H34	Drive sprocket	47	AM-2620-DGB-H47	Bushing
35	AM-2620-DGB-H35	Chain	48	AM-2620-DGB-H48	Pin
36	AM-2620-DGB-H36	Driving gear	49	AM-2620-DGB-H49	Iron shell oil seal
37	AM-2620-DGB-H37	Drive shaft I	50	AM-2620-DGB-H50	Circlips for holes
38	AM-2620-DGB-H38	Driven bevel gear	51	AM-2620-DGB-H51	Deep groove ball bearings
39	AM-2620-DGB-H39	Oil plug	52	AM-2620-DGB-H52	Driven sprocket
			53	AM-2620-DGB-H53	Hexagonal output shaft

SPARE PARTS DIAGRAM & PART LIST OF AM-2620-DGB-9D/6D TRANSMISSION

SUPPORT FRAME PARTS -K

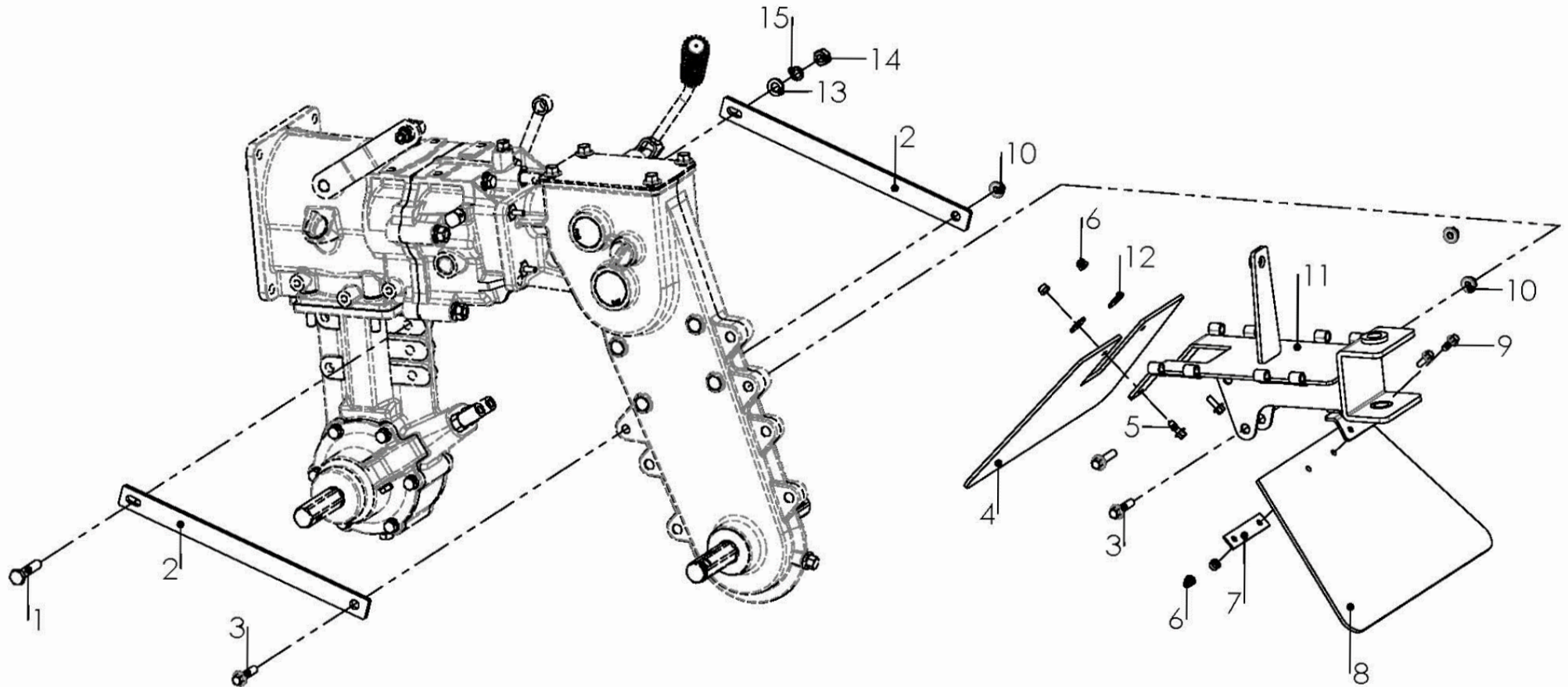

SPARE PARTS DIAGRAM & PART LIST OF AM-2620-DGB-9D/6D TRANSMISSION

SL NO	PART NO	DESCRIPTION	SL NO	PART NO	DESCRIPTION
1	AM-2620-DGB-K01	Hexagon head bolts full thread			
2	AM-2620-DGB-K02	Box connecting plate			
3	AM-2620-DGB-K03	Hexagon flange bolt small series			
4	AM-2620-DGB-K04	Front mudguard rubber			
5	AM-2620-DGB-K05	Hexagon flange bolts, enlarged series, grade B,			
6	AM-2620-DGB-K06	Hexagon lock nuts with non-metallic insert			
7	AM-2620-DGB-K07	Rubber block layering			
8	AM-2620-DGB-K08	Mudguard rubber plate/inner			
9	AM-2620-DGB-K09	Hex Flange Bolt Increased Series B Grade			
10	AM-2620-DGB-K10	Type 2 hexagon flange nut			
11	AM-2620-DGB-K11	Support frame			
12	AM-2620-DGB-K12	Extra large washers			
13	AM-2620-DGB-K13	Flat washer			
14	AM-2620-DGB-K14	Hex nut			
15	AM-2620-DGB-K15	Spring washer			

SPARE PARTS DIAGRAM & PART LIST OF AM-2620-DGB-9D/6D TRANSMISSION

BREAKING SHOVEL PARTS-M

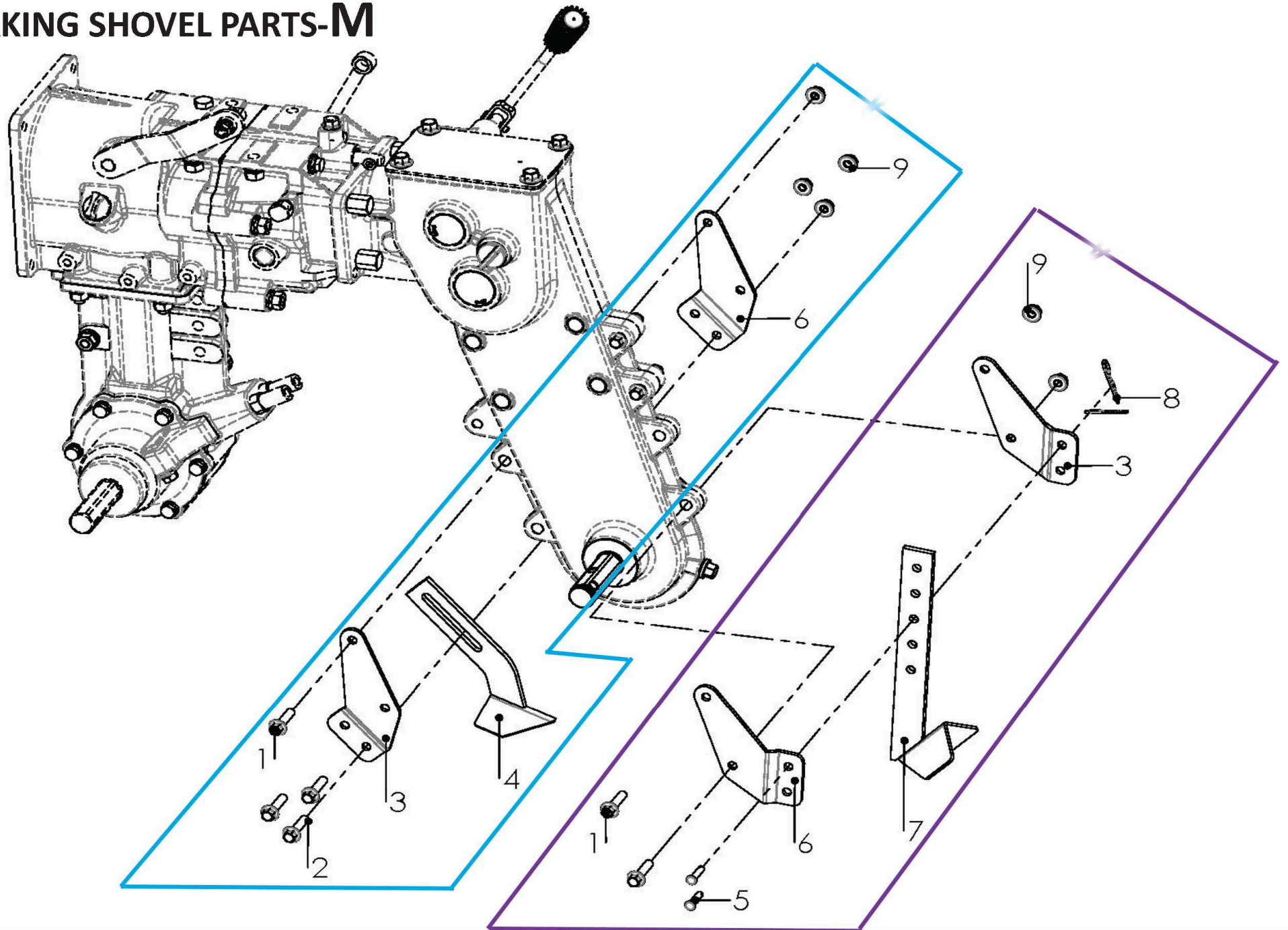

SPARE PARTS DIAGRAM & PART LIST OF AM-2620-DGB-9D/6D TRANSMISSION

SL NO	PART NO	DESCRIPTION	SL NO	PART NO	DESCRIPTION
1	AM-2620-DGB-M01	Hexagon flange bolt			
2	AM-2620-DGB-M02	Hexagon flange bolt			
3	AM-2620-DGB-M03	Trencher shovel connecting plate/right			
4	AM-2620-DGB-M04	Groundbreaking shovel			
5	AM-2620-DGB-M05	Pin			
6	AM-2620-DGB-M06	Trencher Breaking Shovel Connecting Plate/Left			
7	AM-2620-DGB-M07	Groundbreaking shovel			
8	AM-2620-DGB-M08	Circlip B			
9	AM-2620-DGB-M09	Type 2 hexagon flange nut			

SPARE PARTS DIAGRAM & PART LIST OF AM-2620-DGB-9D/6D TRANSMISSION

CULTIVATING BLADES -N

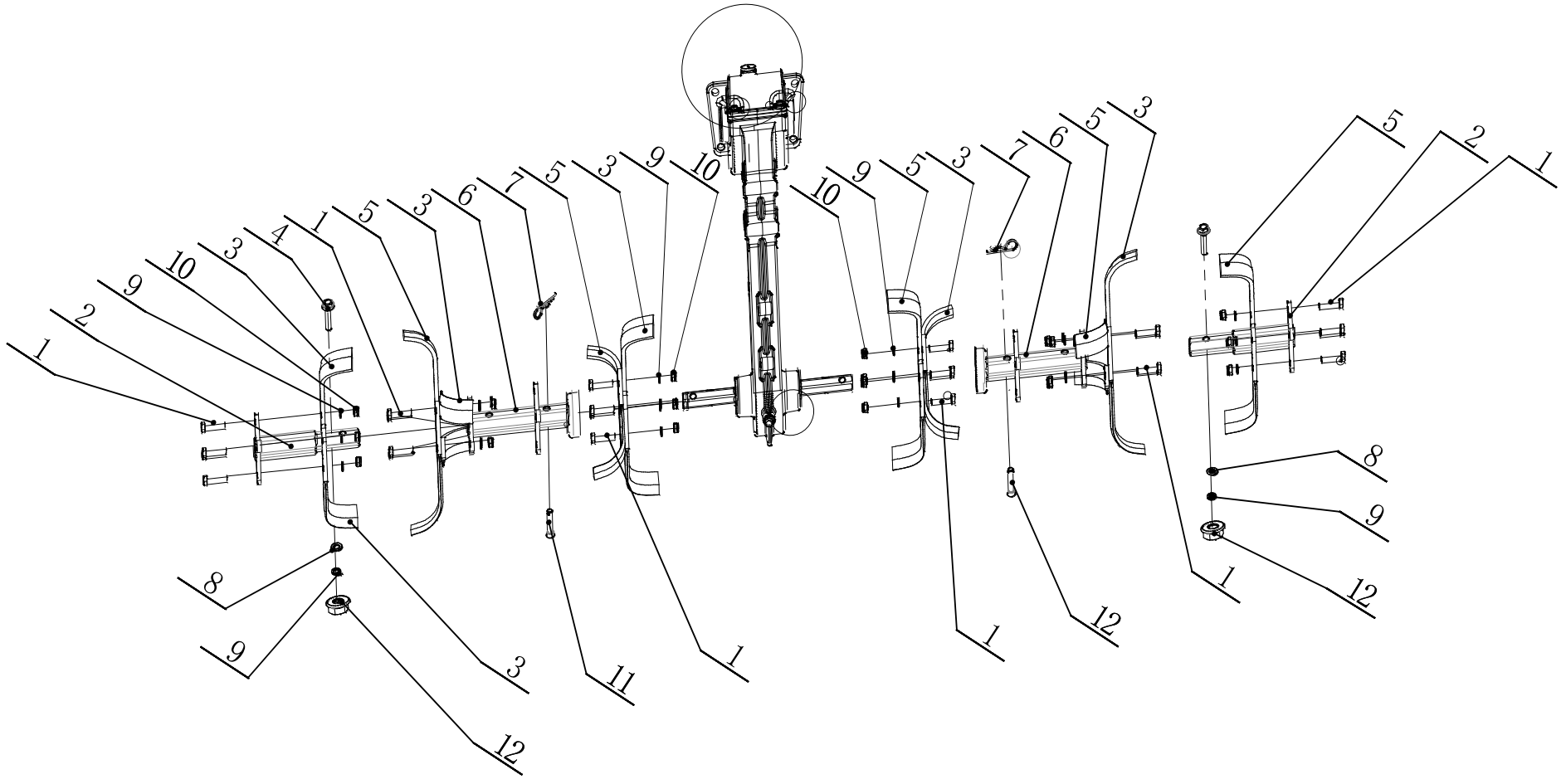

SPARE PARTS DIAGRAM & PART LIST OF AM-2620-DGB-9D/6D TRANSMISSION

SL NO	PART NO	DESCRIPTION	SL NO	PART NO	DESCRIPTION
1	AM-2620-DGB-N01	Hexagon head bolts full thread			
2	AM-2620-DGB-N02	Vice knife barrel			
3	AM-2620-DGB-N03	Rotary tiller right blade			
4	AM-2620-DGB-N04	Hexagon flange bolt			
5	AM-2620-DGB-N05	Rotary tiller left blade			
6	AM-2620-DGB-N06	Main knife barrel			
7	AM-2620-DGB-N07	Circlip B			
8	AM-2620-DGB-N08	Flat washer A grade			
9	AM-2620-DGB-N09	Spring washer			
10	AM-2620-DGB-N10	Hexagon lock nuts with non-metallic inserts			
11	AM-2620-DGB-N11	Pin			
12	AM-2620-DGB-N12	Hexagon flange nut			

SPARE PARTS DIAGRAM & PART LIST OF AM-2620-DGB-9D/6D TRANSMISSION

BLADE PARTS-NA

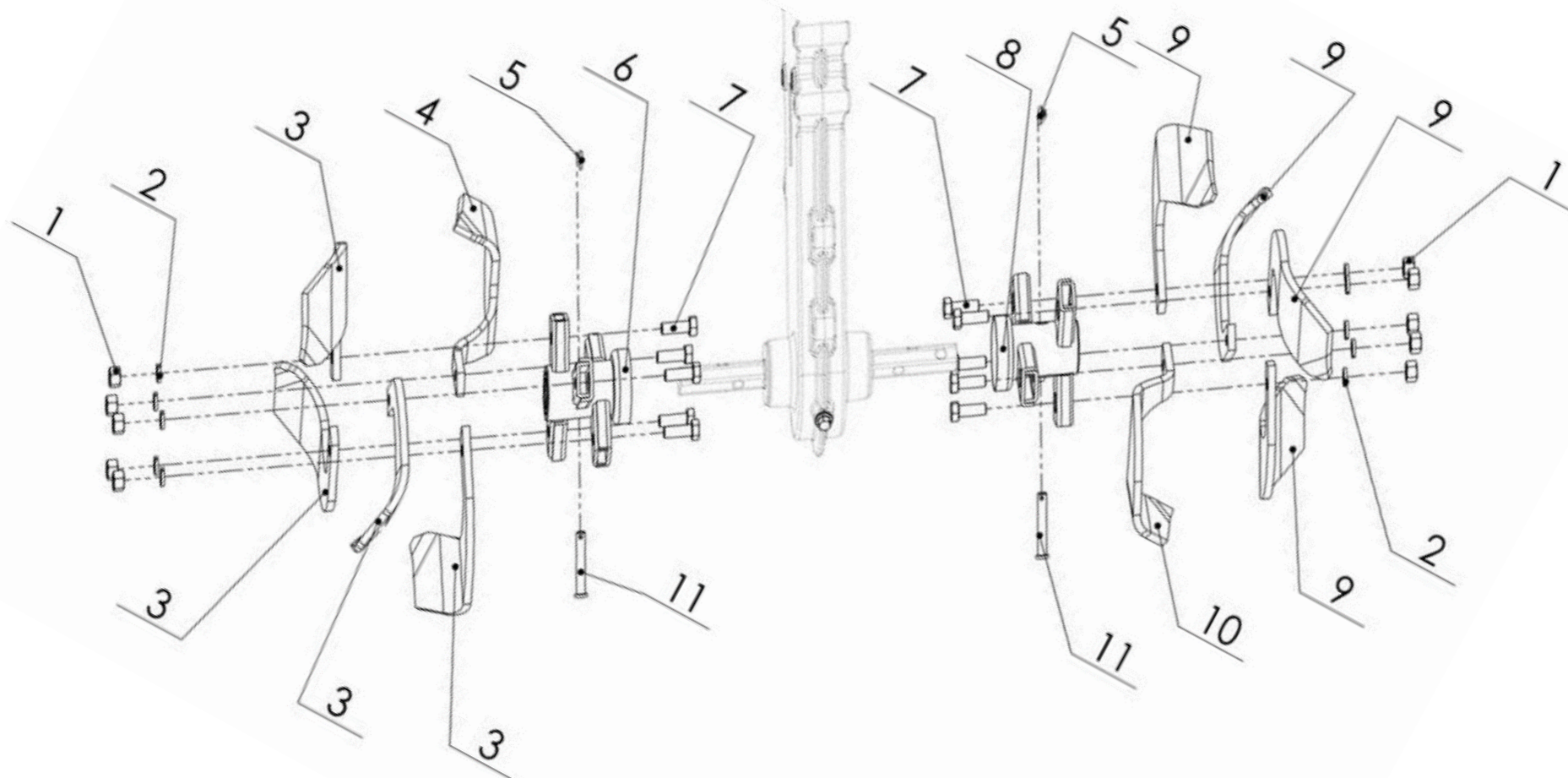

SPARE PARTS DIAGRAM & PART LIST OF AM-2620-DGB-9D/6D TRANSMISSION

SL NO	PART NO	DESCRIPTION	SL NO	PART NO	DESCRIPTION
1	AM-2620-DGB-NA01	Type 1 hexagon nut			
2	AM-2620-DGB-NA02	Standard spring washer			
3	AM-2620-DGB-NA03	Flat grooving knife left knife			
4	AM-2620-DGB-NA04	Bowl-shaped ditching knife left knife			
5	AM-2620-DGB-NA05	Circlip B			
6	AM-2620-DGB-NA06	Five-piece ditching left knife barrel			
7	AM-2620-DGB-NA07	Hexagon head bolts full thread			
8	AM-2620-DGB-NA08	Five-piece ditching right knife barrel			
9	AM-2620-DGB-NA09	Flat grooving knife right knife			
10	AM-2620-DGB-NA10	Bowl-shaped grooving knife right knife			
11	AM-2620-DGB-NA11	Pin			

SPARE PARTS DIAGRAM & PART LIST OF AM-2620-DGB-9D/6D TRANSMISSION

MUDGUARD PARTS -P

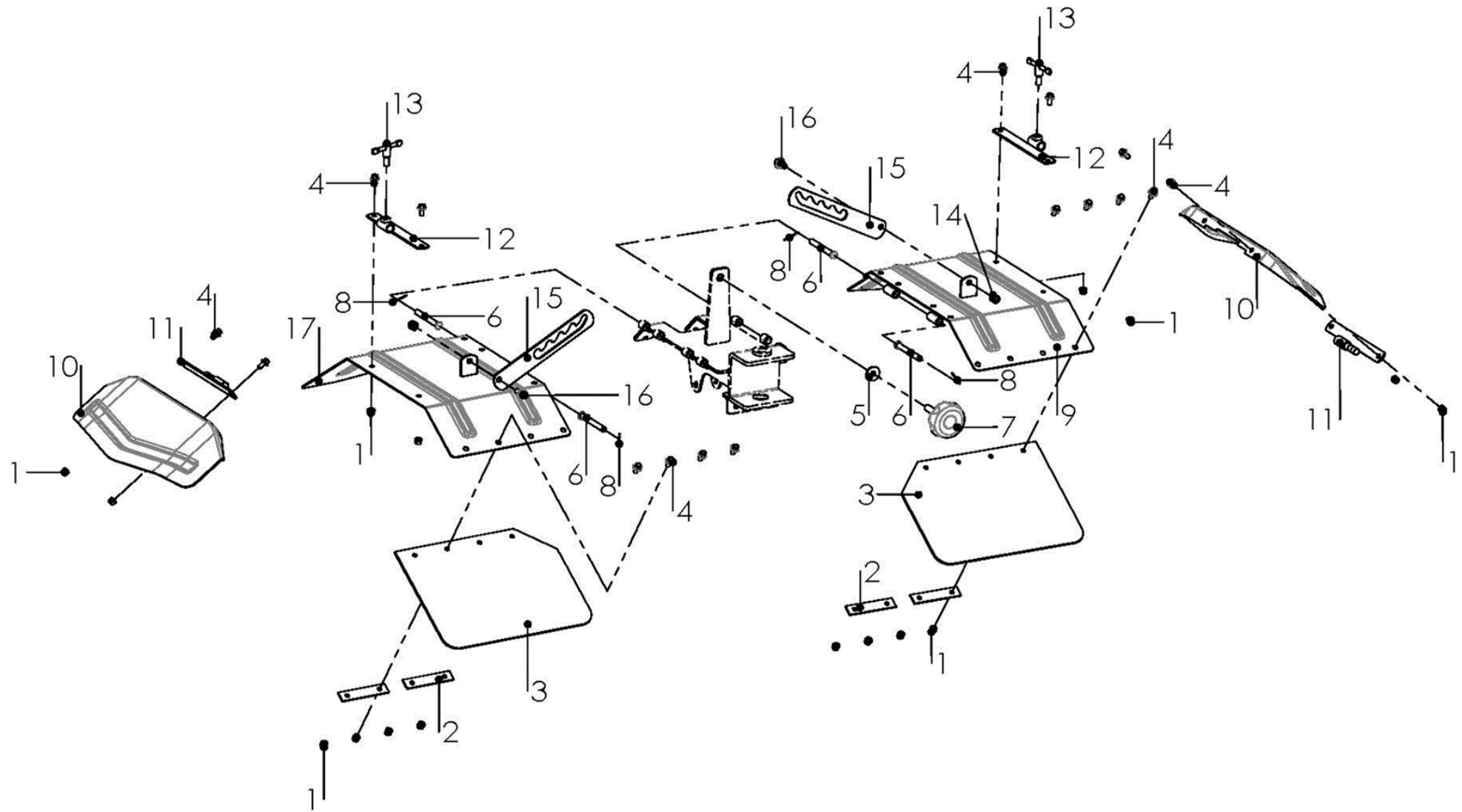

SPARE PARTS DIAGRAM & PART LIST OF AM-2620-DGB-9D/6D TRANSMISSION

SL NO	PART NO	DESCRIPTION	SL NO	PART NO	DESCRIPTION
1	AM-2620-DGB-P01	Hexagon lock nuts with non-metallic insert			
2	AM-2620-DGB-P02	Rubber block layering			
3	AM-2620-DGB-P03	Mudguard rubber plate/outer			
4	AM-2620-DGB-P04	Hex Flange Bolt Increased Series B Grade			
5	AM-2620-DGB-P05	Large flat washer			
6	AM-2620-DGB-P06	Pin			
7	AM-2620-DGB-P07	Adjusting block locking handle			
8	AM-2620-DGB-P08	Split pin			
9	AM-2620-DGB-P09	Right mudguard			
10	AM-2620-DGB-P10	Side mudguard			
11	AM-2620-DGB-P11	Hinge A			
12	AM-2620-DGB-P12	Hinge B			
13	AM-2620-DGB-P13	Lock the small handle			
14	AM-2620-DGB-P14	Hexagon lock nuts with non-metallic inserts			
15	AM-2620-DGB-P15	Mudguard angle adjustment block			
16	AM-2620-DGB-P16	Hexagon flange bolt small series			
17	AM-2620-DGB-P17	Left fender			

SPARE PARTS DIAGRAM & PART LIST OF AM-2620-DGB-9D/6D TRANSMISSION

REAR WHEEL PARTS-R

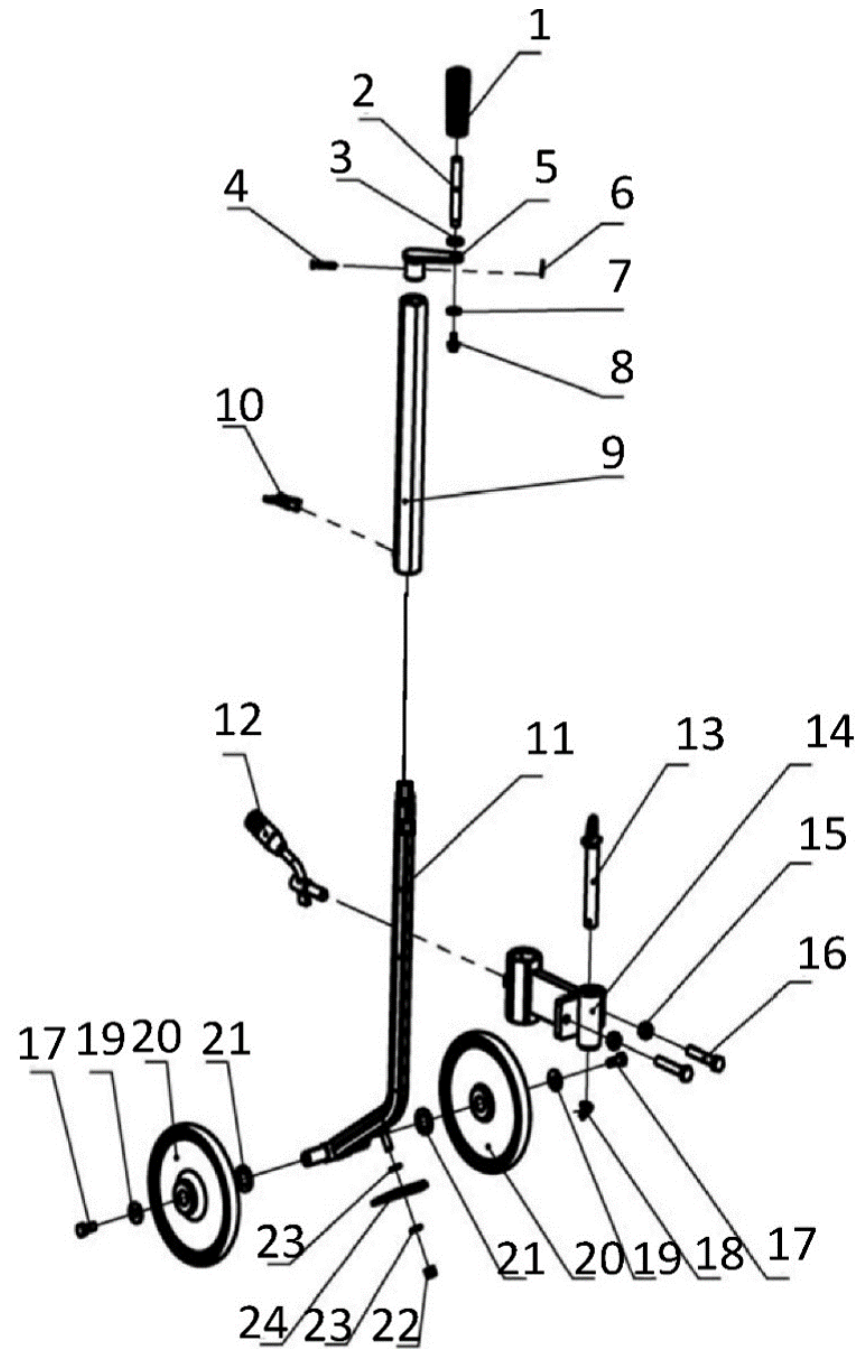

SPARE PARTS DIAGRAM & PART LIST OF AM-2620-DGB-9D/6D TRANSMISSION

SL NO	PART NO	DESCRIPTION	SL NO	PART NO	DESCRIPTION
1	AM-2620-DGB-R01	Shock absorption grip	13	AM-2620-DGB-R13	Bolt with ring
2	AM-2620-DGB-R02	Adjusting handle connecting rod	14	AM-2620-DGB-R14	E type connecting frame
3	AM-2620-DGB-R03	Flat washer	15	AM-2620-DGB-R15	Hex nut
4	AM-2620-DGB-R04	Pin shaft	16	AM-2620-DGB-R16	Hexagon head bolt
5	AM-2620-DGB-R05	Adjusting handle connecting block	17	AM-2620-DGB-R17	Hexagon head bolt
6	AM-2620-DGB-R06	Circlip A	18	AM-2620-DGB-R18	Circlip B
7	AM-2620-DGB-R07	Large flat washer	19	AM-2620-DGB-R19	Large washers
8	AM-2620-DGB-R08	Hexagon flange bolt	20	AM-2620-DGB-R20	Rear wheel
9	AM-2620-DGB-R09	Rear wheel extension connecting rod	21	AM-2620-DGB-R21	Flat washer
10	AM-2620-DGB-R10	Lock the small handle	22	AM-2620-DGB-R22	Hexagon lock nuts with non-metallic inserts
11	AM-2620-DGB-R11	Depth-limiting wheel bracket combination	23	AM-2620-DGB-R23	Flat washer
12	AM-2620-DGB-R12	Locking handle of resistance tillage knife	24	AM-2620-DGB-R24	Mudguard

SPARE PARTS DIAGRAM & PART LIST OF AM-2620-DGB-9D/6D TRANSMISSION

BUMPER PARTS-S

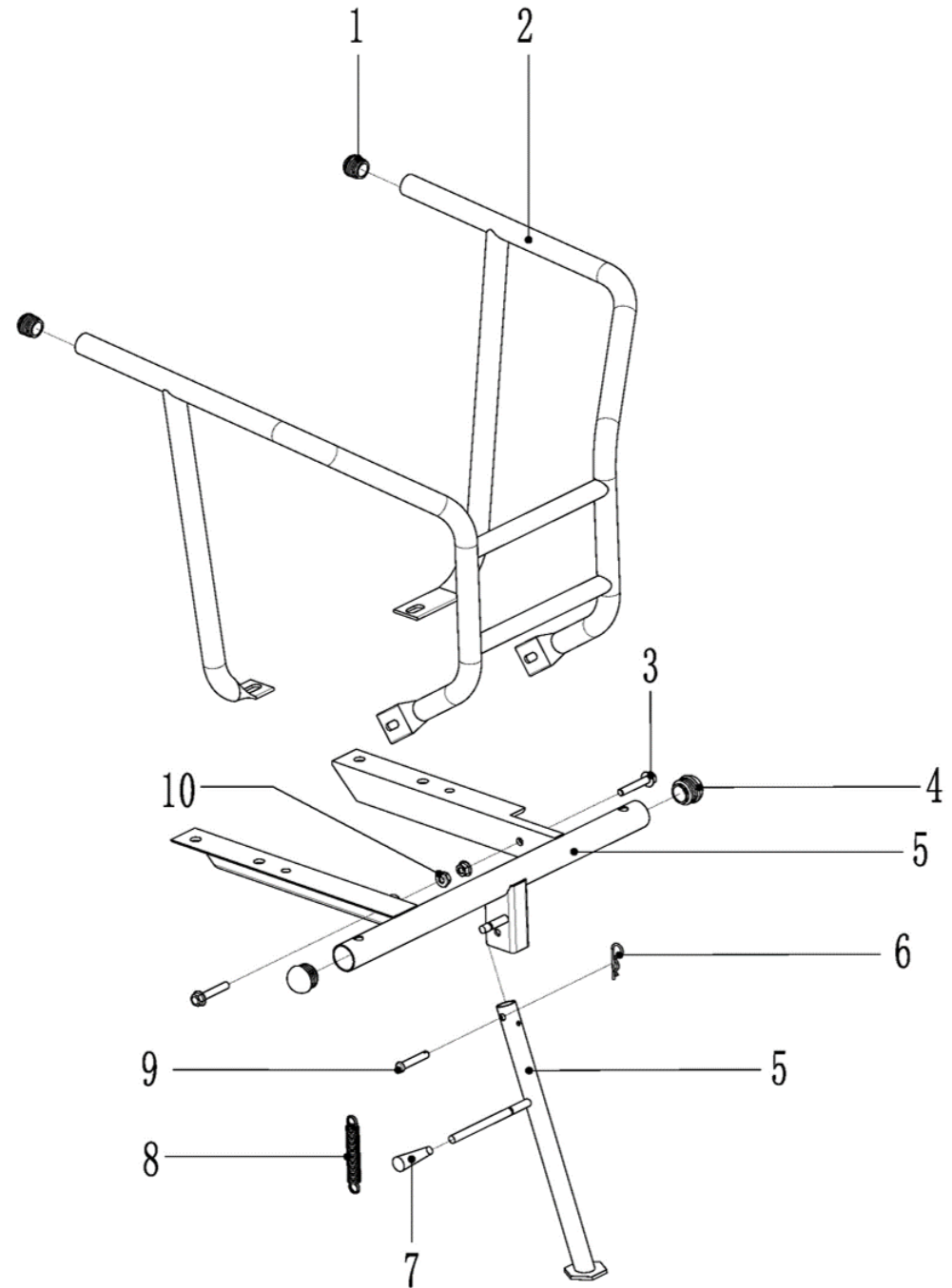
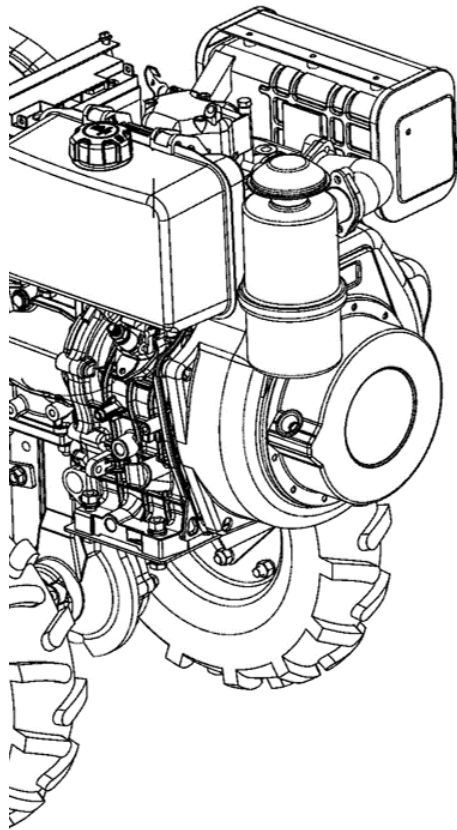

SPARE PARTS DIAGRAM & PART LIST OF AM-2620-DGB-9D/6D TRANSMISSION

SL NO	PART NO	DESCRIPTION	SL NO	PART NO	DESCRIPTION
1	AM-2620-DGB-S01	Bumper plug			
2	AM-2620-DGB-S02	Upper bumper			
3	AM-2620-DGB-S03	Hexagon flange bolt M			
4	AM-2620-DGB-S04	Bumper plug			
5	AM-2620-DGB-S05	Lower bumper			
6	AM-2620-DGB-S06	Circlip B			
7	AM-2620-DGB-S07	Small crank rubber sleeve			
8	AM-2620-DGB-S08	Support leg extension spring			
9	AM-2620-DGB-S09	Pin			
10	AM-2620-DGB-S10	Hexagon flange nut			

wheel assy - T

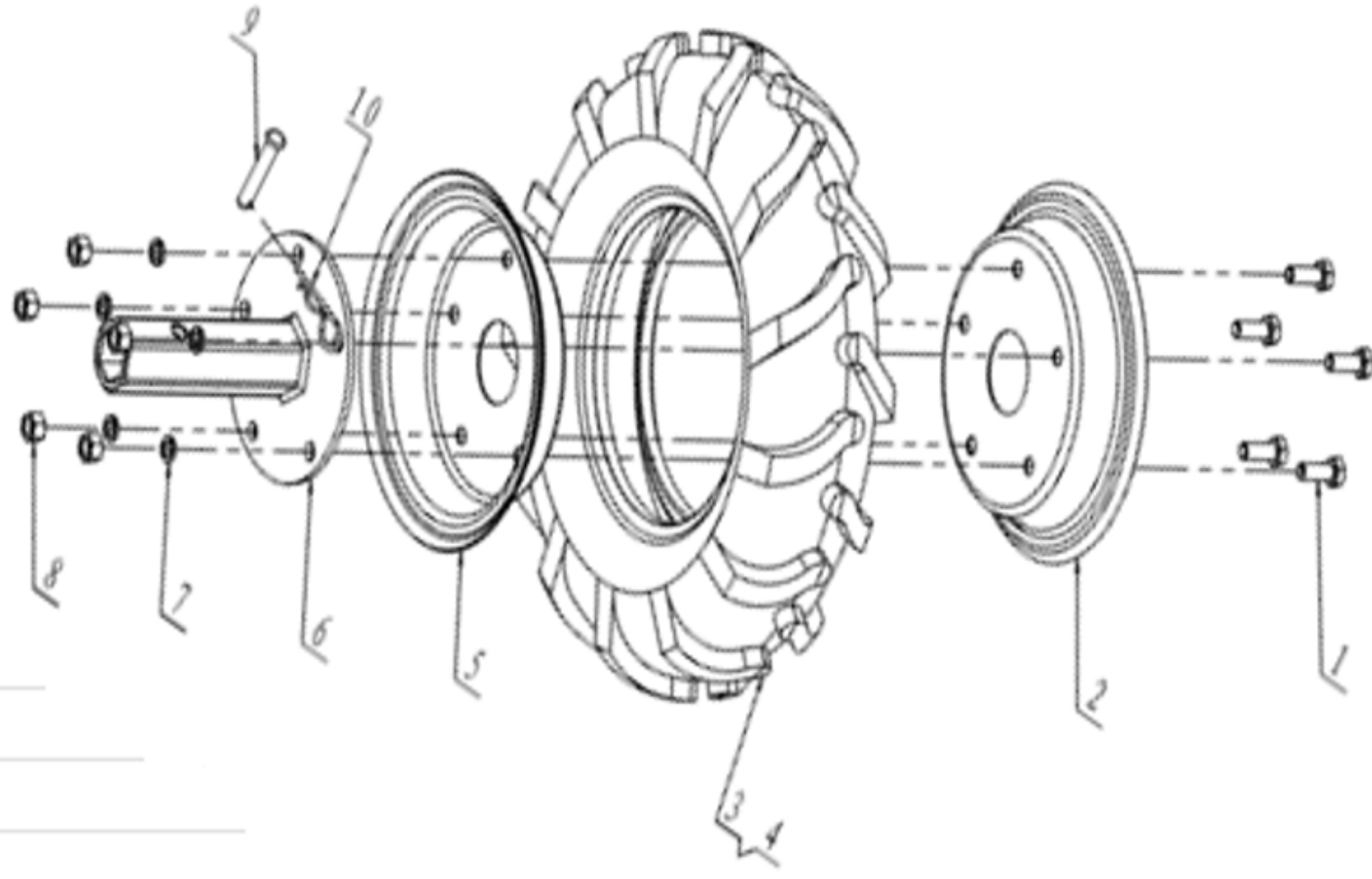

SL NO	PART NO	DESCRIPTION	SL NO	PART NO	DESCRIPTION
1	AM-2620-DGB-T01	Hexagon head bolts-full thread			
2	AM-2620-DGB-T02	Spoke (outer side with hole),4.0-8 wheel			
3	AM-2620-DGB-T03	Tire & Tube 1Set			
4					
5	AM-2620-DGB-T05	Spoke (inner side),4.0-8 wheel			
6	AM-2620-DGB-T06	Wheel axle			
7	AM-2620-DGB-T07	spring washer (standard)			
8	AM-2620-DGB-T08	Hex nut (C grade,1 type)			
9	AM-2620-DGB-T09	Pin			
10	AM-2620-DGB-T10	Clip B			
11					
12					
13					
14					
15					
16					

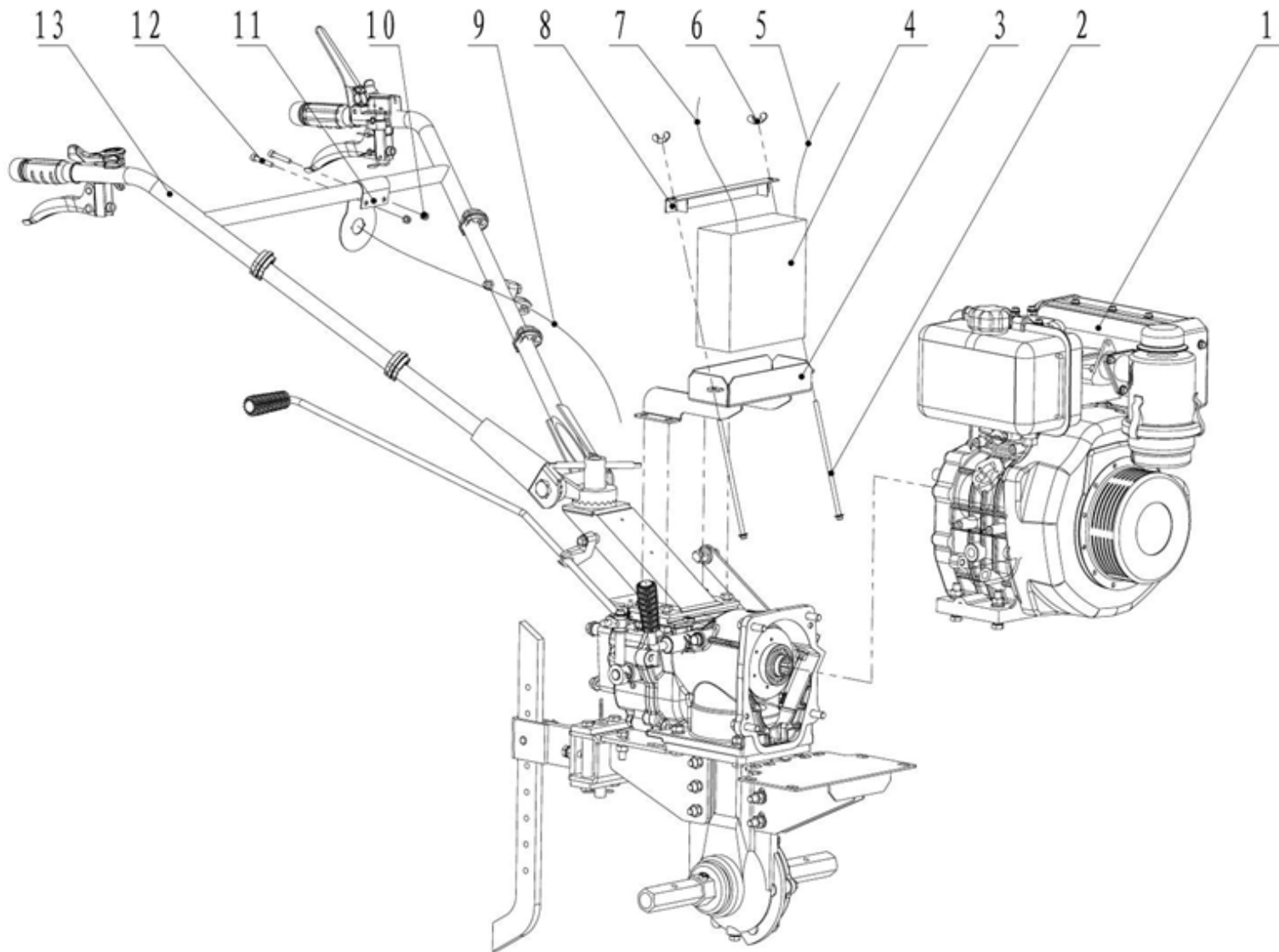

ELECTRIC START -U



SL NO	PART NO	DESCRIPTION	SL NO	PART NO	DESCRIPTION
1	M-2620-DGB-U01A	178FE diesel engine			
	AM-2620-DGB-U01B	186FBE diesel engine			
2	AM-2620-DGB-U02A	Bolt			
	AM-2620-DGB-U02B	Bolt			
3	AM-2620-DGB-U03A	II battery(Higher)			
	AM-2620-DGB-U03B	III battery box			
4	AM-2620-DGB-U04A	18Ah battery			
	AM-2620-DGB-U04B	36Ah battery			
5	AM-2620-DGB-U05A	Battery cable			
	AM-2620-DGB-U05B	Battery cable			
6	AM-2620-DGB-U06	Butterfly nut			
7	AM-2620-DGB-U07A	Battery cable			
	AM-2620-DGB-U07B	Battery cable			
8	AM-2620-DGB-U08A	Battery press piece			
	AM-2620-DGB-U08B	Battery press piece			
9	AM-2620-DGB-U09	Electric start controlling cable			
10	AM-2620-DGB-U10	Locked nut			
11	AM-2620-DGB-U11	electric start limit block			
12	AM-2620-DGB-U12	Bolt			
13	AM-2620-DGB-U13	NA			



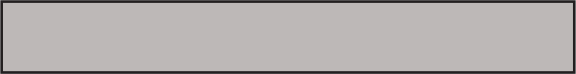
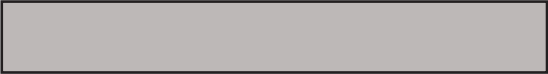
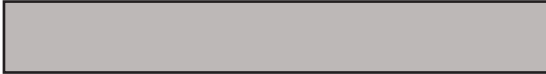

WARRANTY CARD

CUSTOMER COPY

DATE _____	DATE OF DELIVERY _____	DEALERS OFFICIAL SEAL	DEALERS SIGN _____
PURCHASERS NAME & ADDRESS _____ _____	 CUSTOMER SIGN		
PRODUCT NAME	PRODUCT SERIAL NO.	INVOICE/DN NO.	
			

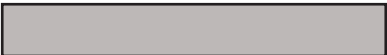



I/Will accept the terms and conditions of warranty as in the warranty card

DEALERS COPY

DATE _____	DATE OF DELIVERY _____	DEALERS OFFICIAL SEAL	DEALERS SIGN _____
PURCHASERS NAME & ADDRESS _____ _____	 CUSTOMER SIGN		
PRODUCT NAME	PRODUCT SERIAL NO.	INVOICE/DN NO.	
			

I/Will accept the terms and conditions of warranty as in the warranty card

COMPANY COPY

DATE _____	DATE OF DELIVERY _____	DEALERS OFFICIAL SEAL	DEALERS SIGN _____
PURCHASERS NAME & ADDRESS _____ _____	 CUSTOMER SIGN		
PRODUCT NAME	PRODUCT SERIAL NO.	INVOICE/DN NO.	
			

I/Will accept the terms and conditions of warranty as in the warranty card

1. LIMITED WARRANTY PERIOD : For a period of six months from the date of Sale / delivery of the product which ever is earlier. 2. LIMITED WARRANTY OBLIGATION : Replacement of defective part(s) by authorized dealer are free of charges. If found defective by reasons of defective material / poor workmanship, parts will be replaced and there will be no value re-imburement. 3. TERMS & CONDITIONS : a. Claims under warranty will be accepted on submission of Warranty Card duly filled and stamped by authorized dealer together with the original purchase document. : b. Shipping / transportation / Incidental charges incurred in replacing defective parts under warranty shall be borne by the purchaser

WARRANTY null & void if

- (i) Lack of maintenance, (ii) Incorrect use of the machine or tampering, (iii) Use of non-genuine spare parts, (iv) Usage of acids, solvents, or any flammable materials, (v) Non-usage of filter water / clear water / soft water & using water above 40°C temperature, (vi) While using the pressure washers to draw water which is contaminated with dust & solvents (eg. paint thinners, gasoline, oil, etc.), (vii) Repair done by unauthorized service people, (viii) Those parts subject to wear & tear due to normal operations and plastic parts, rubber items etc, (ix) Loose connections, faulty electrical fixtures & fluctuations in power supply.
- 4. Should any failure occur during or after the warranty period, customer does not have the right to interrupt payment / price discount.
- 5. Incidental or consequential damages like inconvenience commercial loss, loss of tie, mental agony etc.
- 6. Loss of any nature due to operation or non-operation is not covered under warranty.
- 7. All free service are at Dealer's service point only.
- 8. Warranty ceases if service is not done periodically.
- 9. The attached card should be completed and returned to Ratnagiri Impex Pvt. Ltd. for registration immediately after sale / delivery.
- 10. The warranty is void unless you register the warranty card with Ratnagiri Impex Pvt. Ltd.
- 11. The decision of Ratnagiri Impex Pvt. Ltd., in settling the warranty is final in all respects.
- 12. All disputes are subject to Bangalore Courts Jurisdiction

1. LIMITED WARRANTY PERIOD : For a period of six months from the date of Sale / delivery of the product which ever is earlier. 2. LIMITED WARRANTY OBLIGATION : Replacement of defective part(s) by authorized dealer are free of charges. If found defective by reasons of defective material / poor workmanship, parts will be replaced and there will be no value re-imburement. 3. TERMS & CONDITIONS : a. Claims under warranty will be accepted on submission of Warranty Card duly filled and stamped by authorized dealer together with the original purchase document. : b. Shipping / transportation / Incidental charges incurred in replacing defective parts under warranty shall be borne by the purchaser.

WARRANTY null & void if

- (i) Lack of maintenance, (ii) Incorrect use of the machine or tampering, (iii) Use of non-genuine spare parts, (iv) Usage of acids, solvents, or any flammable materials, (v) Non-usage of filter water / clear water / soft water & using water above 40°C temperature, (vi) While using the pressure washers to draw water which is contaminated with dust & solvents (eg. paint thinners, gasoline, oil, etc.), (vii) Repair done by unauthorized service people, (viii) Those parts subject to wear & tear due to normal operations and plastic parts, rubber items etc, (ix) Loose connections, faulty electrical fixtures & fluctuations in power supply.
- 4. Should any failure occur during or after the warranty period, customer does not have the right to interrupt payment / price discount.
- 5. Incidental or consequential damages like inconvenience commercial loss, loss of tie, mental agony etc.
- 6. Loss of any nature due to operation or non-operation is not covered under warranty.
- 7. All free service are at Dealer's service point only.
- 8. Warranty ceases if service is not done periodically.
- 9. The attached card should be completed and returned to Ratnagiri Impex Pvt. Ltd. for registration immediately after sale / delivery.
- 10. The warranty is void unless you register the warranty card with Ratnagiri Impex Pvt. Ltd.
- 11. The decision of Ratnagiri Impex Pvt. Ltd., in settling the warranty is final in all respects.
- 12. All disputes are subject to Bangalore Courts Jurisdiction

1. LIMITED WARRANTY PERIOD : For a period of six months from the date of Sale / delivery of the product which ever is earlier. 2. LIMITED WARRANTY OBLIGATION : Replacement of defective part(s) by authorized dealer are free of charges. If found defective by reasons of defective material / poor workmanship, parts will be replaced and there will be no value re-imburement. 3. TERMS & CONDITIONS : a. Claims under warranty will be accepted on submission of Warranty Card duly filled and stamped by authorized dealer together with the original purchase document. : b. Shipping / transportation / Incidental charges incurred in replacing defective parts under warranty shall be borne by the purchaser.

WARRANTY null & void if

- (i) Lack of maintenance, (ii) Incorrect use of the machine or tampering, (iii) Use of non-genuine spare parts, (iv) Usage of acids, solvents, or any flammable materials, (v) Non-usage of filter water / clear water / soft water & using water above 40°C temperature, (vi) While using the pressure washers to draw water which is contaminated with dust & solvents (eg. paint thinners, gasoline, oil, etc.), (vii) Repair done by unauthorized service people, (viii) Those parts subject to wear & tear due to normal operations and plastic parts, rubber items etc, (ix) Loose connections, faulty electrical fixtures & fluctuations in power supply.
- 4. Should any failure occur during or after the warranty period, customer does not have the right to interrupt payment / price discount.
- 5. Incidental or consequential damages like inconvenience commercial loss, loss of tie, mental agony etc.
- 6. Loss of any nature due to operation or non-operation is not covered under warranty.
- 7. All free service are at Dealer's service point only.
- 8. Warranty ceases if service is not done periodically.
- 9. The attached card should be completed and returned to Ratnagiri Impex Pvt. Ltd. for registration immediately after sale / delivery.
- 10. The warranty is void unless you register the warranty card with Ratnagiri Impex Pvt. Ltd.
- 11. The decision of Ratnagiri Impex Pvt. Ltd., in settling the warranty is final in all respects.
- 12. All disputes are subject to Bangalore Courts Jurisdiction



FREE SERVICE COUPON (30DAYS/30HRS. WHICHEVER IS EARLIER)

MODEL

SERIAL NUMBER

PDI DATE

SERVICE NO.

PURCHASE BILL NO.

DATE

DEALERS OFFICE SEAL

- 1. Check and test the fuel mixture
- 3. Check , clean and adjust the spark plug
- 5. Check and sparken the cutting tools
- 7. Start and check the noise, vibration, loosen etc..

OPERATIONS

- 2. check and clean the air filter
- 4. Check and adjust the carburetor tuning
- 6. Product familirisation on usage
- 8. Routine maintenance and shortage.

FREE SERVICE COUPON (30DAYS/30HRS. WHICHEVER IS EARLIER)

MODEL

SERIAL NUMBER

PDI DATE

SERVICE NO.

PURCHASE BILL NO.

DATE

DEALERS OFFICE SEAL

- 1. Check and test the fuel mixture
- 3. Check , clean and adjust the spark plug
- 5. Check and sparken the cutting tools
- 7. Start and check the noise, vibration, loosen etc..

OPERATIONS

- 2. check and clean the air filter
- 4. Check and adjust the carburetor tuning
- 6. Product familirisation on usage
- 8. Routine maintenance and shortage.

FREE SERVICE COUPON (30DAYS/30HRS. WHICHEVER IS EARLIER)

MODEL

SERIAL NUMBER

PDI DATE

SERVICE NO.

PURCHASE BILL NO.

DATE

DEALERS OFFICE SEAL

- 1. Check and test the fuel mixture
- 3. Check , clean and adjust the spark plug
- 5. Check and sparken the cutting tools
- 7. Start and check the noise, vibration, loosen etc..

OPERATIONS

- 2. check and clean the air filter
- 4. Check and adjust the carburetor tuning
- 6. Product familirisation on usage
- 8. Routine maintenance and shortage.

DOS

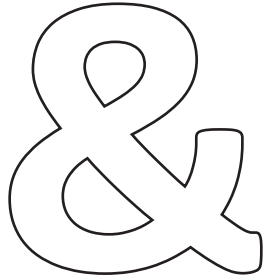

DONT'S

1. Always read the instruction manual supplied along with the equipments and understand the correct installation and operating procedures before attempting to use the equipments.
2. It is important to use the personal protection equipments such as head helmet with visor, ear defenders, goggles, safety gloves, cut resistant shoes, trousers and jackets while operating potentially dangerous machines
3. Avoid untrained persons using the equipments. Children must not be allowed to handle these equipments
4. Always use genuine spares and accessories in repairs and usage to derive maximum life of the equipments.
5. Always keep the equipments in good working condition to minimize loss of output as well as to reduce the pollution and save the environment
6. Do not use the machine within range of persons unless they wear protective clothing
7. Do not operate the machine when fatigued or under the influence of alcohol or drugs
8. When the machine is running, please maintain a constant water supply. Without water circulation will damage the sealing rings of the machine.
9. For more query kindly contact for our Service Center/Dealer/ franchise

Agrimate Army For Pest Control

ANY WHERE - ANY TIME - ANY CROP

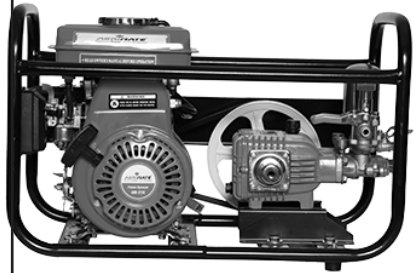
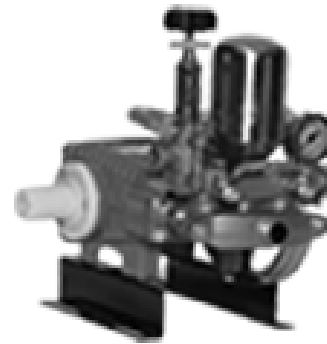

Marketed by:
**ratnagiri
impex**
BRINGING YOU THE FUTURE... NOW

RATNAGIRI IMPEX PVT., LTD.,

Annapurna House, #1 / 1G, 7th Cross, New
Guddadahalli

Mysore Road, Bangalore - 560 026

Missed Call : 7393 938 938

Email: ask@agrimart.in