

PADDY THRESHER WITH ENGINE/MOTOR

AM-PTMG-500-3HPM

AM-PTMG-500-3HPM



INTRODUCTION

Dear Sir/ Madam,

Thank you for choosing Agrimate product. You are the proud owner of high technology & durable machine. Trust that our Franchisee/Dealer installed the product & installed the product and explained you about the usage & service instructions. Please visit our autorised dealer for your future requirement of our other equipments, genuine spares, accessories and services. Service coupons are attached with this manual and you can avail free service to keep your machine fit always to use on demand.

About Ratnagiri,

We import and market of high quality of agriculture wide range of equipments which we are selling through our authorised franchisee or dealer network. We are in this field from past years service the farmer. community. For further details, Please visit our website www.agrimart.in. & Give a missed call to 7393 938 938.

TECHNICAL SPECIFICATIONS

PADDY THRESHER WITH ENGINE / MOTOR		
MODEL	AM-PTMG- 500-170EN	AM-PTMG- 500-3HPM
POWER	7HP	2.2KW/3HP
PRODUCTIVITY	500-750KG/H	500-750KG/H
TOTAL WEIGHT	65KG	72KG

SPARE PARTS DIAGRAM & PARTS LIST OF PADDY THRESHER

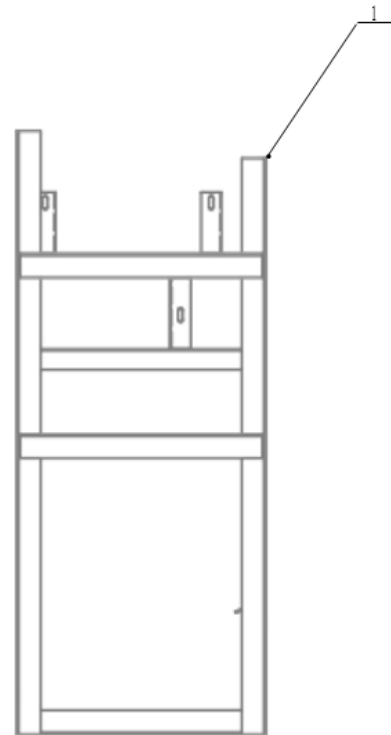
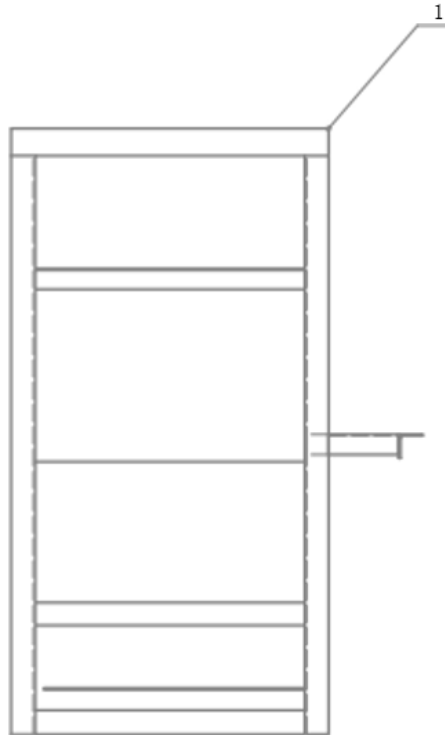

SPARE PARTS DIAGRAM & PARTS LIST OF PADDY THRESHER

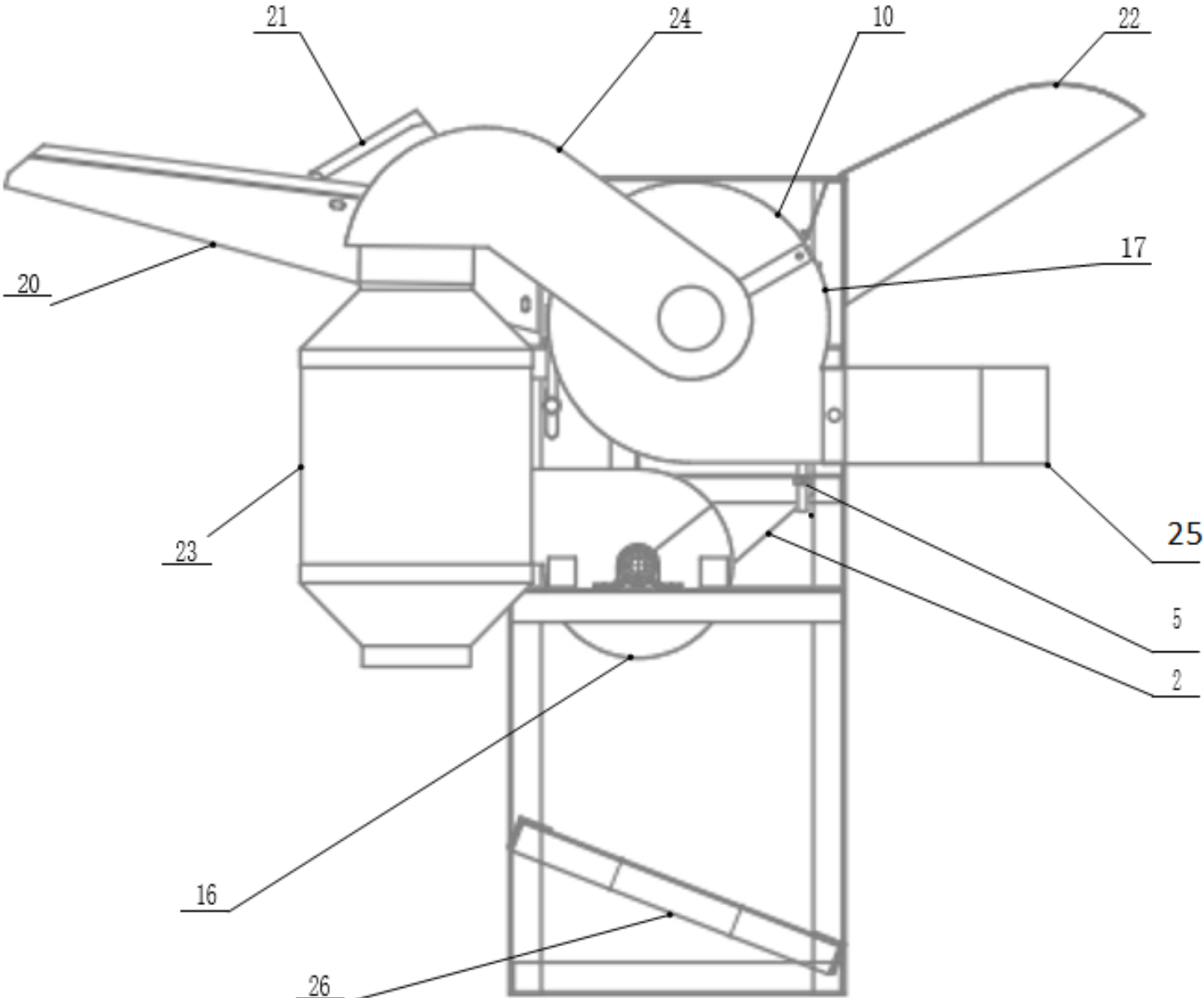

SPARE PARTS DIAGRAM & PARTS LIST OF PADDY THRESHER

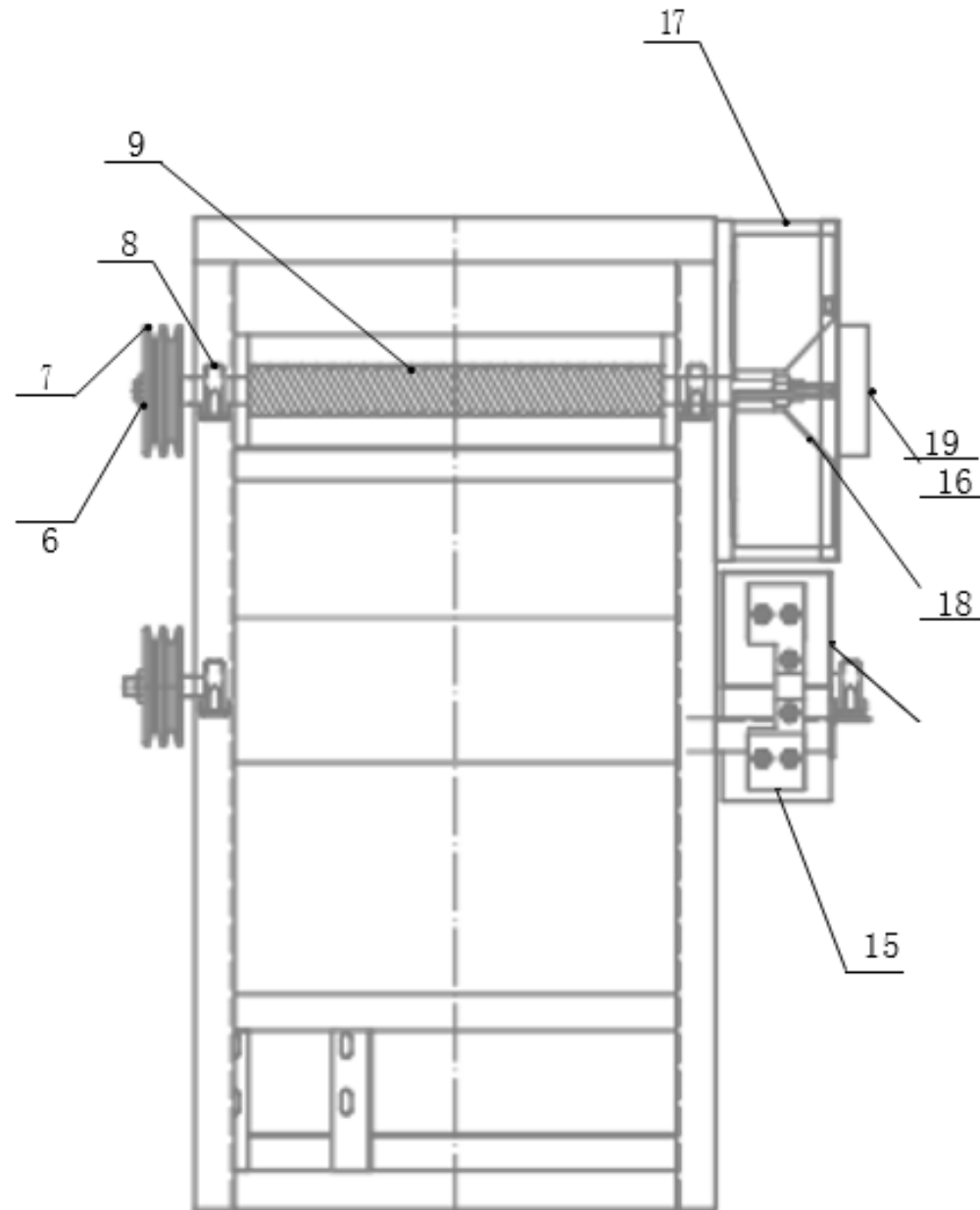

SPARE PARTS DIAGRAM & PARTS LIST OF PADDY THRESHER

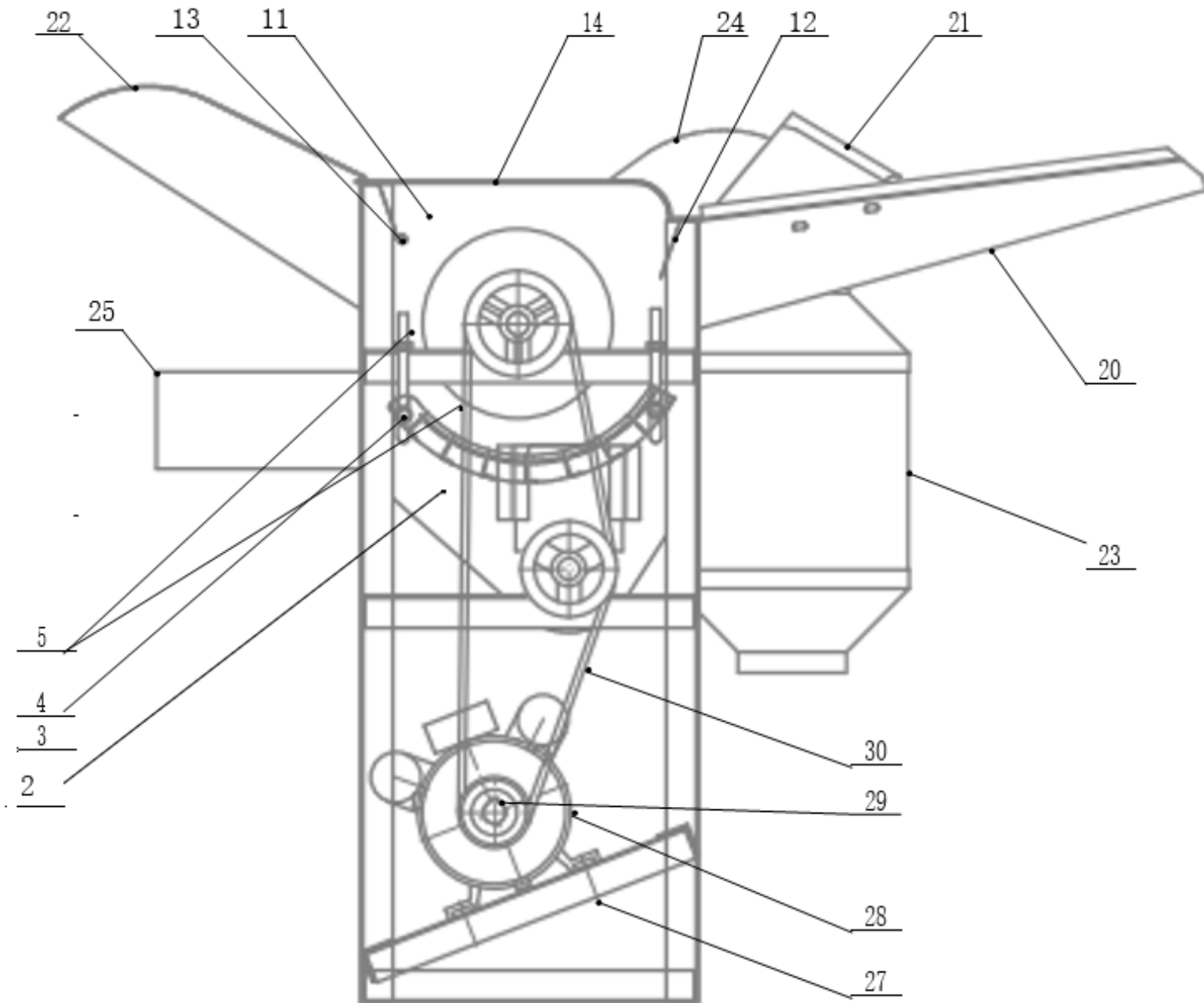





SPARE PARTS DIAGRAM & PARTS LIST OF PADDY THRESHER

SL NO	PART NO	DESCRIPTION	SL NO	PART NO	DESCRIPTION
1	AM-PTMG-T01	Frame	16	AM-PTMG-T16	Fan casing of outlet
2	AM-PTMG-T02	Seperating Tank	17	AM-PTMG-T17	Fan casing
3	AM-PTMG-T03	Sieve	18	AM-PTMG-T18	Fan pulley
4	AM-PTMG-T04	Rod	19	AM-PTMG-T19	Fan Cover
5	AM-PTMG-T05	Movable joint	20	AM-PTMG-T20	Feed hopper
6	AM-PTMG-T06	Nut	21	AM-PTMG-T21	Feed cover
7	AM-PTMG-T07	Roller Pulley	22	AM-PTMG-T22	Outlet Cover
8	AM-PTMG-T08	Bearing	23	AM-PTMG-T23	Separation tank
9	AM-PTMG-T09	Roller	24	AM-PTMG-T24	Air Channel
10	AM-PTMG-T10	Superior right spectum	25	AM-PTMG-T25	Outlet
11	AM-PTMG-T11	Lower right spectum	26	AM-PTMG-T26	Motor Bar-Left
12	AM-PTMG-T12	Baffle of feed hopper	27	AM-PTMG-T27	Motor Bar-right
13	AM-PTMG-T13	Baffle of outlet	28	AM-PTMG-T28	Motor
14	AM-PTMG-T14	Top Cover	29	AM-PTMG-T29	Motor Pulley
15	AM-PTMG-T15	Screw shaft set	30	AM-PTMG-T30	Triangle Belt





WARRANTY CARD

CUSTOMER COPY

DATE _____	DATE OF DELIVERY _____	DEALERS OFFICIAL SEAL	DEALERS SIGN _____
PURCHASERS NAME & ADDRESS _____ _____	 CUSTOMER SIGN		
PRODUCT NAME	PRODUCT SERIAL NO.	INVOICE/DN NO.	
			





I/Will accept the terms and conditions of warranty as in the warranty card

DEALERS COPY

DATE _____	DATE OF DELIVERY _____	DEALERS OFFICIAL SEAL	DEALERS SIGN _____
PURCHASERS NAME & ADDRESS _____ _____	 CUSTOMER SIGN		
PRODUCT NAME	PRODUCT SERIAL NO.	INVOICE/DN NO.	
			

I/Will accept the terms and conditions of warranty as in the warranty card

COMPANY COPY

DATE _____	DATE OF DELIVERY _____	DEALERS OFFICIAL SEAL	DEALERS SIGN _____
PURCHASERS NAME & ADDRESS _____ _____	 CUSTOMER SIGN		
PRODUCT NAME	PRODUCT SERIAL NO.	INVOICE/DN NO.	
			

I/Will accept the terms and conditions of warranty as in the warranty card

1. LIMITED WARRANTY PERIOD : For a period of six months from the date of Sale / delivery of the product which ever is earlier. 2. LIMITED WARRANTY OBLIGATION : Replacement of defective part(s) by authorized dealer are free of charges. If found defective by reasons of defective material / poor workmanship, parts will be replaced and there will be no value re-imburement. 3. TERMS & CONDITIONS : a. Claims under warranty will be accepted on submission of Warranty Card duly filled and stamped by authorized dealer together with the original purchase document. : b. Shipping / transportation / Incidental charges incurred in replacing defective parts under warranty shall be borne by the purchaser

WARRANTY null & void if

- (i) Lack of maintenance, (ii) Incorrect use of the machine or tampering, (iii) Use of non-genuine spare parts, (iv) Usage of acids, solvents, or any flammable materials, (v) Non-usage of filter water / clear water / soft water & using water above 40°C temperature, (vi) While using the pressure washers to draw water which is contaminated with dust & solvents (eg. paint thinners, gasoline, oil, etc.), (vii) Repair done by unauthorized service people, (viii) Those parts subject to wear & tear due to normal operations and plastic parts, rubber items etc, (ix) Loose connections, faulty electrical fixtures & fluctuations in power supply.
- 4. Should any failure occur during or after the warranty period, customer does not have the right to interrupt payment / price discount.
- 5. Incidental or consequential damages like inconvenience commercial loss, loss of tie, mental agony etc.
- 6. Loss of any nature due to operation or non-operation is not covered under warranty.
- 7. All free service are at Dealer's service point only.
- 8. Warranty ceases if service is not done periodically.
- 9. The attached card should be completed and returned to Ratnagiri Impex Pvt. Ltd. for registration immediately after sale / delivery.
- 10. The warranty is void unless you register the warranty card with Ratnagiri Impex Pvt. Ltd.
- 11. The decision of Ratnagiri Impex Pvt. Ltd., in settling the warranty is final in all respects.
- 12. All disputes are subject to Bangalore Courts Jurisdiction

1. LIMITED WARRANTY PERIOD : For a period of six months from the date of Sale / delivery of the product which ever is earlier. 2. LIMITED WARRANTY OBLIGATION : Replacement of defective part(s) by authorized dealer are free of charges. If found defective by reasons of defective material / poor workmanship, parts will be replaced and there will be no value re-imburement. 3. TERMS & CONDITIONS : a. Claims under warranty will be accepted on submission of Warranty Card duly filled and stamped by authorized dealer together with the original purchase document. : b. Shipping / transportation / Incidental charges incurred in replacing defective parts under warranty shall be borne by the purchaser.

WARRANTY null & void if

- (i) Lack of maintenance, (ii) Incorrect use of the machine or tampering, (iii) Use of non-genuine spare parts, (iv) Usage of acids, solvents, or any flammable materials, (v) Non-usage of filter water / clear water / soft water & using water above 40°C temperature, (vi) While using the pressure washers to draw water which is contaminated with dust & solvents (eg. paint thinners, gasoline, oil, etc.), (vii) Repair done by unauthorized service people, (viii) Those parts subject to wear & tear due to normal operations and plastic parts, rubber items etc, (ix) Loose connections, faulty electrical fixtures & fluctuations in power supply.
- 4. Should any failure occur during or after the warranty period, customer does not have the right to interrupt payment / price discount.
- 5. Incidental or consequential damages like inconvenience commercial loss, loss of tie, mental agony etc.
- 6. Loss of any nature due to operation or non-operation is not covered under warranty.
- 7. All free service are at Dealer's service point only.
- 8. Warranty ceases if service is not done periodically.
- 9. The attached card should be completed and returned to Ratnagiri Impex Pvt. Ltd. for registration immediately after sale / delivery.
- 10. The warranty is void unless you register the warranty card with Ratnagiri Impex Pvt. Ltd.
- 11. The decision of Ratnagiri Impex Pvt. Ltd., in settling the warranty is final in all respects.
- 12. All disputes are subject to Bangalore Courts Jurisdiction

1. LIMITED WARRANTY PERIOD : For a period of six months from the date of Sale / delivery of the product which ever is earlier. 2. LIMITED WARRANTY OBLIGATION : Replacement of defective part(s) by authorized dealer are free of charges. If found defective by reasons of defective material / poor workmanship, parts will be replaced and there will be no value re-imburement. 3. TERMS & CONDITIONS : a. Claims under warranty will be accepted on submission of Warranty Card duly filled and stamped by authorized dealer together with the original purchase document. : b. Shipping / transportation / Incidental charges incurred in replacing defective parts under warranty shall be borne by the purchaser.

WARRANTY null & void if

- (i) Lack of maintenance, (ii) Incorrect use of the machine or tampering, (iii) Use of non-genuine spare parts, (iv) Usage of acids, solvents, or any flammable materials, (v) Non-usage of filter water / clear water / soft water & using water above 40°C temperature, (vi) While using the pressure washers to draw water which is contaminated with dust & solvents (eg. paint thinners, gasoline, oil, etc.), (vii) Repair done by unauthorized service people, (viii) Those parts subject to wear & tear due to normal operations and plastic parts, rubber items etc, (ix) Loose connections, faulty electrical fixtures & fluctuations in power supply.
- 4. Should any failure occur during or after the warranty period, customer does not have the right to interrupt payment / price discount.
- 5. Incidental or consequential damages like inconvenience commercial loss, loss of tie, mental agony etc.
- 6. Loss of any nature due to operation or non-operation is not covered under warranty.
- 7. All free service are at Dealer's service point only.
- 8. Warranty ceases if service is not done periodically.
- 9. The attached card should be completed and returned to Ratnagiri Impex Pvt. Ltd. for registration immediately after sale / delivery.
- 10. The warranty is void unless you register the warranty card with Ratnagiri Impex Pvt. Ltd.
- 11. The decision of Ratnagiri Impex Pvt. Ltd., in settling the warranty is final in all respects.
- 12. All disputes are subject to Bangalore Courts Jurisdiction



FREE SERVICE COUPON (30DAYS/30HRS. WHICHEVER IS EARLIER)

MODEL	<input type="text"/>	SERIAL NUMBER	<input type="text"/>
PDI DATE	SERVICE NO.	PURCHASE BILL NO.	DATE
<input type="text"/>	<input type="text"/>	<input type="text"/>	<input type="text"/>
DEALERS OFFICE SEAL	OPERATIONS		
<input type="text"/>	<ol style="list-style-type: none"> 1. Check and test the fuel mixture 3. Check , clean and adjust the spark plug 5. Check and sparken the cutting tools 7. Start and check the noise, vibration, loosen etc.. 	<ol style="list-style-type: none"> 2. check and clean the air filter 4. Check and adjust the carburetor tuning 6. Product familirisation on usage 8. Routine maintenance and shortage. 	

FREE SERVICE COUPON (30DAYS/30HRS. WHICHEVER IS EARLIER)

MODEL	<input type="text"/>	SERIAL NUMBER	<input type="text"/>
PDI DATE	SERVICE NO.	PURCHASE BILL NO.	DATE
<input type="text"/>	<input type="text"/>	<input type="text"/>	<input type="text"/>
DEALERS OFFICE SEAL	OPERATIONS		
<input type="text"/>	<ol style="list-style-type: none"> 1. Check and test the fuel mixture 3. Check , clean and adjust the spark plug 5. Check and sparken the cutting tools 7. Start and check the noise, vibration, loosen etc.. 	<ol style="list-style-type: none"> 2. check and clean the air filter 4. Check and adjust the carburetor tuning 6. Product familirisation on usage 8. Routine maintenance and shortage. 	

FREE SERVICE COUPON (30DAYS/30HRS. WHICHEVER IS EARLIER)

MODEL	<input type="text"/>	SERIAL NUMBER	<input type="text"/>
PDI DATE	SERVICE NO.	PURCHASE BILL NO.	DATE
<input type="text"/>	<input type="text"/>	<input type="text"/>	<input type="text"/>
DEALERS OFFICE SEAL	OPERATIONS		
<input type="text"/>	<ol style="list-style-type: none"> 1. Check and test the fuel mixture 3. Check , clean and adjust the spark plug 5. Check and sparken the cutting tools 7. Start and check the noise, vibration, loosen etc.. 	<ol style="list-style-type: none"> 2. check and clean the air filter 4. Check and adjust the carburetor tuning 6. Product familirisation on usage 8. Routine maintenance and shortage. 	

DOS

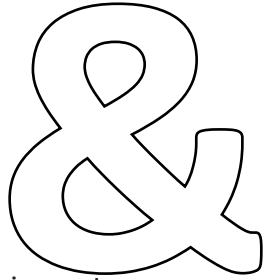

DONTs

attempting to use the equipments.

1. Always read the instruction manual supplied along with the equipments and understand the correct installation and operating procedures before

trousers and jackets while operating potentially dangerous machines
2. It is important to use the personal protection equipments such as head helmet with visor, ear defenders, goggles, safety gloves, cut resistant shoes,
3. Avoid untrained persons using the equipments. Children must not be allowed to handle these equipments
4. Always use genuine spares and accessories in repairs and usage to derive maximum life of the equipments.
5. Always keep the equipments in good working condition to minimize loss of output as well as to reduce the pollution and save the environment
6. Do not use the machine within range of persons unless they wear protective clothing
7. Do not operate the machine when fatigued or under the influence of alcohol or drugs
8. For more query kindly contact for our Service Center/Dealer/ franchise

NO. 1 CHOICE OF FARMERS SINCE 1999



Marketed by.
**ratnagiri
impex**
BRINGING YOU THE FUTURE... NOW

RATNAGIRI IMPEX PVT., LTD.,

Annapurna House, #1 / 1G, 7th Cross, New
Guddadahalli

Mysore Road, Bangalore - 560 026

Missed Call : 7393 938 938

Email: ask@agrimart.in