

INTERCULTIVATOR/POWER WEEDER AM-RTP-7P- MAX ENGINE PART DIAGRAM

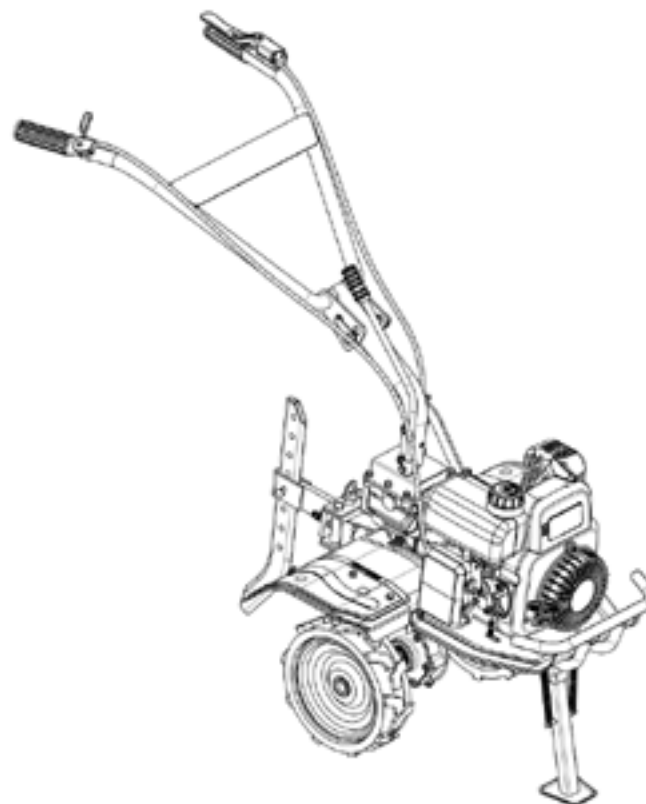

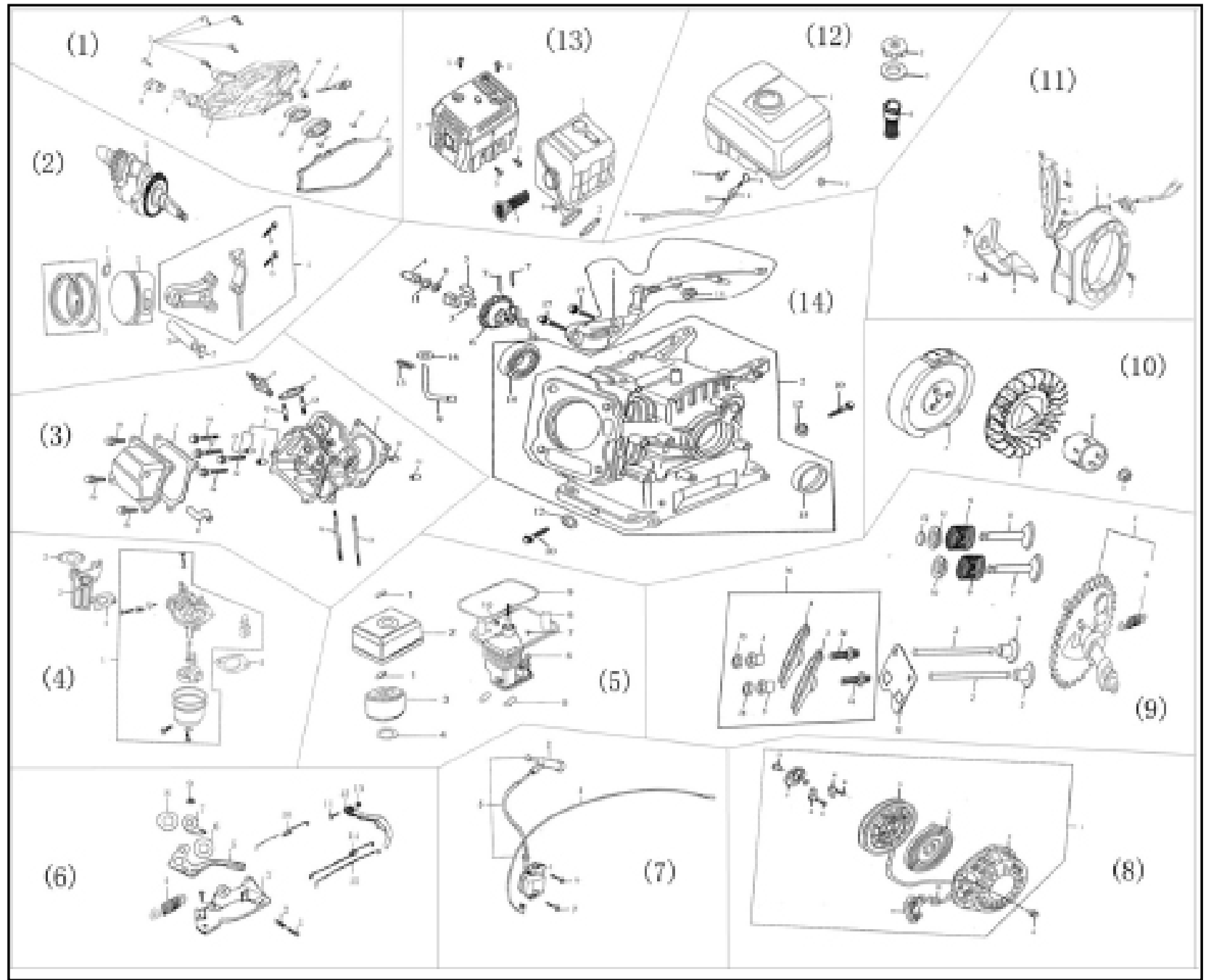

Side cover assembly - A

SL NO	PART NO	DESCRIPTION	SL NO	PART NO	DESCRIPTION
1	AM-170FPM-EA01	Crankcase cover assy	8	AM-170FPM-EA08	Radial ball bearing
2	AM-170FPM-EA02	Case cover packing	9	AM-170FPM-EA09	Oil plug
3	AM-170FPM-EA03	Oil filler cap assy			
4	AM-170FPM-EA04	Oil filler cap packing			
5	AM-170FPM-EA05	Oil seal			
6	AM-170FPM-EA06	Dowel pin			
7	AM-170FPM-EA07	Bolt			

Crank shaft,Piston, Connector - B

SL NO	PART NO	DESCRIPTION	SL NO	PART NO	DESCRIPTION
1	AM-170FPM-EB01	Pinston rings			
2	AM-170FPM-EB02	Piston			
3	AM-170FPM-EB03	Piston pin			
4	AM-170FPM-EB04	Tie-rod assy			
5	AM-170FPM-EB05	Crankshaft sets			
6	AM-170FPM-EB06	Connect rod blot			
7	AM-170FPM-EB07	Piston pin circlip			

Cylinder head and Cylinder head cover - C

SL NO	PART NO	DESCRIPTION	SL NO	PART NO	DESCRIPTION
1	AM-170FPM-EC01	Intake valve guide	9	AM-170FPM-EC09	Exhaust valve gasket
2	AM-170FPM-EC02	Exhaust valve guide	10	AM-170FPM-EC10	Valve cover bolt
3	AM-170FPM-EC03	Cylinder head assy	11	AM-170FPM-EC11	Stud
4	AM-170FPM-EC04	Spark plug	12	AM-170FPM-EC12	Stud
5	AM-170FPM-EC05	Gasket(cylinder head)	13	AM-170FPM-EC13	Dowel pin
6	AM-170FPM-EC06	Cylinder head cover	14	AM-170FPM-EC14	Head bolt
7	AM-170FPM-EC07	Gasket(cylinder head cover)	15	AM-170FPM-EC15	Exhaust valve circip
8	AM-170FPM-EC08	Breather hose			

Carburator - D

SL NO	PART NO	DESCRIPTION	SL NO	PART NO	DESCRIPTION
1	AM-170FPM-ED01	Carbuetor			
2	AM-170FPM-ED02	Gasket(carburetor-outside)			
3	AM-170FPM-ED03	Insulator(carburetor)			
4	AM-170FPM-ED04	Gasket(carburetor inside)			
5	AM-170FPM-ED05	Gasket(air			

Air filter - E

SL NO	PART NO	DESCRIPTION	SL NO	PART NO	DESCRIPTION
1	AM-170FPM-EE01	NUT	7	AM-170FPM-EE07	BOLT
2	AM-170FPM-EE02	Air cleaner cover	8	AM-170FPM-EE08	Air cleaner bottom cover
3	AM-170FPM-EE03	Element of air cleaner	9	AM-170FPM-EE09	Gasket
4	AM-170FPM-EE04	Washer	10	AM-170FPM-EE10	Collar B
5	AM-170FPM-EE05	Air cleaner Collar A			
6	AM-170FPM-EE06	Air cleaner base			

RPM adjustable assembly - F

SL NO	PART NO	DESCRIPTION	SL NO	PART NO	DESCRIPTION
1	AM-170FPM-EF01	BOLT	9	AM-170FPM-EF09	Nut
2	AM-170FPM-EF02	Governor spring	10	AM-170FPM-EF10	Governor spring
3	AM-170FPM-EF03	Governor Support plate	11	AM-170FPM-EF11	BOLT
4	AM-170FPM-EF04	Spring(Pull rod)	12	AM-170FPM-EF12	Governor arm
5	AM-170FPM-EF05	Speed controller	13	AM-170FPM-EF13	Nut
6	AM-170FPM-EF06	Washer	14	AM-170FPM-EF14	Reset spring
7	AM-170FPM-EF07	batter board	15	AM-170FPM-EF15	Speed Pull rod
8	AM-170FPM-EF08	Spring lamination			

Ignition assembly - G

SL NO	PART NO	DESCRIPTION	SL NO	PART NO	DESCRIPTION
1	AM-170FPM-EG01	Ignition coil			
2	AM-170FPM-EG02	Spark plug cap			
3	AM-170FPM-EG03	Extinguishing cable			
4	AM-170FPM-EG04	BOLT			
5	AM-170FPM-EG05	Ignition coil unit			

Recoil Assembly - H

SL NO	PART NO	DESCRIPTION	SL NO	PART NO	DESCRIPTION
1	AM-170FPM-EH01	Starter unit	7	AM-170FPM-EH07	Spiral spring
2	AM-170FPM-EH02	Starter housing	8	AM-170FPM-EH08	Friction spring
3	AM-170FPM-EH03	Starter starting roller	9	AM-170FPM-EH09	Starter handle
4	AM-170FPM-EH04	Ratchet	10	AM-170FPM-EH10	Starter rope
5	AM-170FPM-EH05	Ratchet lid	11	AM-170FPM-EH11	Set screw
6	AM-170FPM-EH06	BOLT			

Camshaft and Valve rocker arm - J

SL NO	PART NO	DESCRIPTION	SL NO	PART NO	DESCRIPTION
1	AM-170FPM-EJ01	Camshaft(iron)	9	AM-170FPM-EJ09	Valve spring
2	AM-170FPM-EJ02	Push rod	10	AM-170FPM-EJ10	Retainer intake valve spring
3	AM-170FPM-EJ03	Valve rocker arm	11	AM-170FPM-EJ11	Retainer exhaust valve spring
4	AM-170FPM-EJ04	Valve lifter	12	AM-170FPM-EJ12	Retainer valve rotator
5	AM-170FPM-EJ05	Rocker arm pivot	13	AM-170FPM-EJ13	Plate push rod guide plate
6	AM-170FPM-EJ06	Weight return spring	14	AM-170FPM-EJ14	Pivot bolt
7	AM-170FPM-EJ07	Intake valve	15	AM-170FPM-EJ15	Pivct adjusting nut
8	AM-170FPM-EJ08	Exhaust valve	16	AM-170FPM-EJ16	Valve Rocker arm assy

10. Flywheel assembly - K

SL NO	PART NO	DESCRIPTION	SL NO	PART NO	DESCRIPTION
1	AM-170FPM-EK01	Cooling fan			
2	AM-170FPM-EK02	Starter pulley			
3	AM-170FPM-EK03	Nut			
4	AM-170FPM-EK04	Flywheel			

11. Air Guid assembly - L

SL NO	PART NO	DESCRIPTION	SL NO	PART NO	DESCRIPTION
1	AM-170FPM-EL01	Wind scooper			
2	AM-170FPM-EL02	Flywheel cover			
3	AM-170FPM-EL03	Valve clamp			
4	AM-170FPM-EL04	Air shield			
5	AM-170FPM-EL05	ON/OFF Switch			
6	AM-170FPM-EL06	BOLT			
7	AM-170FPM-EL07	BOLT			

12. Fuel Tank - M

SL NO	PART NO	DESCRIPTION	SL NO	PART NO	DESCRIPTION
1	AM-170FPM-EM01	Fuel tank	7	AM-170FPM-EM07	BOLT
2	AM-170FPM-EM02	Fuel tank cover	8	AM-170FPM-EM08	"O"ring
3	AM-170FPM-EM03	Fuel filler cap packing	9	AM-170FPM-EM09	Tube
4	AM-170FPM-EM04	Fuel cock assy	10	AM-170FPM-EM10	Tube clip
5	AM-170FPM-EM05	Nut			
6	AM-170FPM-EM06	Fuel filter			

13. Muffler - 13





SL NO	PART NO	DESCRIPTION	SL NO	PART NO	DESCRIPTION
1	AM-170FPM-EN01	Muffler			
2	AM-170FPM-EN02	Gasket,exhaust pipe			
3	AM-170FPM-EN03	Insulator(silencer)			
4	AM-170FPM-EN04	Extingtuisher,spark			
5	AM-170FPM-EN05	Bolt			
6	AM-170FPM-EN06	Nut			

14. Crank case assembly - P

SL NO	PART NO	DESCRIPTION	SL NO	PART NO	DESCRIPTION
1	AM-170FPM-EP01	Oil alert	10	AM-170FPM-EP10	Bolt@Drain plug
2	AM-170FPM-EP02	Crankcase	11	AM-170FPM-EP11	Washer
3	AM-170FPM-EP03	Governor gear shaft	12	AM-170FPM-EP12	Washer
4	AM-170FPM-EP04	Governor slide bushing	13	AM-170FPM-EP13	Split pin
5	AM-170FPM-EP05	Governor slider	14	AM-170FPM-EP14	Radial ball bearing
6	AM-170FPM-EP06	Governor gear set	15	AM-170FPM-EP15	Oil seal
7	AM-170FPM-EP07	Slider pin	16	AM-170FPM-EP16	Washer
8	AM-170FPM-EP08	Governor clip	17	AM-170FPM-EP17	Bolt
9	AM-170FPM-EP09	Regulating sway bar	18	AM-170FPM-EP18	Nut





WARRANTY CARD

CUSTOMER COPY

DATE _____	DATE OF DELIVERY _____	DEALERS OFFICIAL SEAL	DEALERS SIGN _____
PURCHASERS NAME & ADDRESS _____ _____	 CUSTOMER SIGN		
PRODUCT NAME	PRODUCT SERIAL NO.	INVOICE/DN NO.	
			





I/Will accept the terms and conditions of warranty as in the warranty card

DEALERS COPY

DATE _____	DATE OF DELIVERY _____	DEALERS OFFICIAL SEAL	DEALERS SIGN _____
PURCHASERS NAME & ADDRESS _____ _____	 CUSTOMER SIGN		
PRODUCT NAME	PRODUCT SERIAL NO.	INVOICE/DN NO.	
			

I/Will accept the terms and conditions of warranty as in the warranty card

COMPANY COPY

DATE _____	DATE OF DELIVERY _____	DEALERS OFFICIAL SEAL	DEALERS SIGN _____
PURCHASERS NAME & ADDRESS _____ _____	 CUSTOMER SIGN		
PRODUCT NAME	PRODUCT SERIAL NO.	INVOICE/DN NO.	
			

I/Will accept the terms and conditions of warranty as in the warranty card

1. LIMITED WARRANTY PERIOD : For a period of six months from the date of Sale / delivery of the product which ever is earlier. 2. LIMITED WARRANTY OBLIGATION : Replacement of defective part(s) by authorized dealer are free of charges. If found defective by reasons of defective material / poor workmanship, parts will be replaced and there will be no value re-imburement. 3. TERMS & CONDITIONS : a. Claims under warranty will be accepted on submission of Warranty Card duly filled and stamped by authorized dealer together with the original purchase document. : b. Shipping / transportation / Incidental charges incurred in replacing defective parts under warranty shall be borne by the purchaser

WARRANTY null & void if

- (i) Lack of maintenance, (ii) Incorrect use of the machine or tampering, (iii) Use of non-genuine spare parts, (iv) Usage of acids, solvents, or any flammable materials, (v) Non-usage of filter water / clear water / soft water & using water above 40°C temperature, (vi) While using the pressure washers to draw water which is contaminated with dust & solvents (eg. paint thinners, gasoline, oil, etc.), (vii) Repair done by unauthorized service people, (viii) Those parts subject to wear & tear due to normal operations and plastic parts, rubber items etc, (ix) Loose connections, faulty electrical fixtures & fluctuations in power supply.
- 4. Should any failure occur during or after the warranty period, customer does not have the right to interrupt payment / price discount.
- 5. Incidental or consequential damages like inconvenience commercial loss, loss of tie, mental agony etc.
- 6. Loss of any nature due to operation or non-operation is not covered under warranty.
- 7. All free service are at Dealer's service point only.
- 8. Warranty ceases if service is not done periodically.
- 9. The attached card should be completed and returned to Ratnagiri Impex Pvt. Ltd. for registration immediately after sale / delivery.
- 10. The warranty is void unless you register the warranty card with Ratnagiri Impex Pvt. Ltd.
- 11. The decision of Ratnagiri Impex Pvt. Ltd., in settling the warranty is final in all respects.
- 12. All disputes are subject to Bangalore Courts Jurisdiction

1. LIMITED WARRANTY PERIOD : For a period of six months from the date of Sale / delivery of the product which ever is earlier. 2. LIMITED WARRANTY OBLIGATION : Replacement of defective part(s) by authorized dealer are free of charges. If found defective by reasons of defective material / poor workmanship, parts will be replaced and there will be no value re-imburement. 3. TERMS & CONDITIONS : a. Claims under warranty will be accepted on submission of Warranty Card duly filled and stamped by authorized dealer together with the original purchase document. : b. Shipping / transportation / Incidental charges incurred in replacing defective parts under warranty shall be borne by the purchaser.

WARRANTY null & void if

- (i) Lack of maintenance, (ii) Incorrect use of the machine or tampering, (iii) Use of non-genuine spare parts, (iv) Usage of acids, solvents, or any flammable materials, (v) Non-usage of filter water / clear water / soft water & using water above 40°C temperature, (vi) While using the pressure washers to draw water which is contaminated with dust & solvents (eg. paint thinners, gasoline, oil, etc.), (vii) Repair done by unauthorized service people, (viii) Those parts subject to wear & tear due to normal operations and plastic parts, rubber items etc, (ix) Loose connections, faulty electrical fixtures & fluctuations in power supply.
- 4. Should any failure occur during or after the warranty period, customer does not have the right to interrupt payment / price discount.
- 5. Incidental or consequential damages like inconvenience commercial loss, loss of tie, mental agony etc.
- 6. Loss of any nature due to operation or non-operation is not covered under warranty.
- 7. All free service are at Dealer's service point only.
- 8. Warranty ceases if service is not done periodically.
- 9. The attached card should be completed and returned to Ratnagiri Impex Pvt. Ltd. for registration immediately after sale / delivery.
- 10. The warranty is void unless you register the warranty card with Ratnagiri Impex Pvt. Ltd.
- 11. The decision of Ratnagiri Impex Pvt. Ltd., in settling the warranty is final in all respects.
- 12. All disputes are subject to Bangalore Courts Jurisdiction

1. LIMITED WARRANTY PERIOD : For a period of six months from the date of Sale / delivery of the product which ever is earlier. 2. LIMITED WARRANTY OBLIGATION : Replacement of defective part(s) by authorized dealer are free of charges. If found defective by reasons of defective material / poor workmanship, parts will be replaced and there will be no value re-imburement. 3. TERMS & CONDITIONS : a. Claims under warranty will be accepted on submission of Warranty Card duly filled and stamped by authorized dealer together with the original purchase document. : b. Shipping / transportation / Incidental charges incurred in replacing defective parts under warranty shall be borne by the purchaser.

WARRANTY null & void if

- (i) Lack of maintenance, (ii) Incorrect use of the machine or tampering, (iii) Use of non-genuine spare parts, (iv) Usage of acids, solvents, or any flammable materials, (v) Non-usage of filter water / clear water / soft water & using water above 40°C temperature, (vi) While using the pressure washers to draw water which is contaminated with dust & solvents (eg. paint thinners, gasoline, oil, etc.), (vii) Repair done by unauthorized service people, (viii) Those parts subject to wear & tear due to normal operations and plastic parts, rubber items etc, (ix) Loose connections, faulty electrical fixtures & fluctuations in power supply.
- 4. Should any failure occur during or after the warranty period, customer does not have the right to interrupt payment / price discount.
- 5. Incidental or consequential damages like inconvenience commercial loss, loss of tie, mental agony etc.
- 6. Loss of any nature due to operation or non-operation is not covered under warranty.
- 7. All free service are at Dealer's service point only.
- 8. Warranty ceases if service is not done periodically.
- 9. The attached card should be completed and returned to Ratnagiri Impex Pvt. Ltd. for registration immediately after sale / delivery.
- 10. The warranty is void unless you register the warranty card with Ratnagiri Impex Pvt. Ltd.
- 11. The decision of Ratnagiri Impex Pvt. Ltd., in settling the warranty is final in all respects.
- 12. All disputes are subject to Bangalore Courts Jurisdiction



FREE SERVICE COUPON (30DAYS/30HRS. WHICHEVER IS EARLIER)

MODEL	<input type="text"/>	SERIAL NUMBER	<input type="text"/>
PDI DATE	SERVICE NO.	PURCHASE BILL NO.	DATE
<input type="text"/>	<input type="text"/>	<input type="text"/>	<input type="text"/>
DEALERS OFFICE SEAL	OPERATIONS		
<input type="text"/>	<ol style="list-style-type: none"> 1. Check and test the fuel mixture 3. Check , clean and adjust the spark plug 5. Check and sparken the cutting tools 7. Start and check the noise, vibration, loosen etc.. 	<ol style="list-style-type: none"> 2. check and clean the air filter 4. Check and adjust the carburetor tuning 6. Product familirisation on usage 8. Routine maintenance and shortage. 	

FREE SERVICE COUPON (30DAYS/30HRS. WHICHEVER IS EARLIER)

MODEL	<input type="text"/>	SERIAL NUMBER	<input type="text"/>
PDI DATE	SERVICE NO.	PURCHASE BILL NO.	DATE
<input type="text"/>	<input type="text"/>	<input type="text"/>	<input type="text"/>
DEALERS OFFICE SEAL	OPERATIONS		
<input type="text"/>	<ol style="list-style-type: none"> 1. Check and test the fuel mixture 3. Check , clean and adjust the spark plug 5. Check and sparken the cutting tools 7. Start and check the noise, vibration, loosen etc.. 	<ol style="list-style-type: none"> 2. check and clean the air filter 4. Check and adjust the carburetor tuning 6. Product familirisation on usage 8. Routine maintenance and shortage. 	

FREE SERVICE COUPON (30DAYS/30HRS. WHICHEVER IS EARLIER)

MODEL	<input type="text"/>	SERIAL NUMBER	<input type="text"/>
PDI DATE	SERVICE NO.	PURCHASE BILL NO.	DATE
<input type="text"/>	<input type="text"/>	<input type="text"/>	<input type="text"/>
DEALERS OFFICE SEAL	OPERATIONS		
<input type="text"/>	<ol style="list-style-type: none"> 1. Check and test the fuel mixture 3. Check , clean and adjust the spark plug 5. Check and sparken the cutting tools 7. Start and check the noise, vibration, loosen etc.. 	<ol style="list-style-type: none"> 2. check and clean the air filter 4. Check and adjust the carburetor tuning 6. Product familirisation on usage 8. Routine maintenance and shortage. 	

DOS

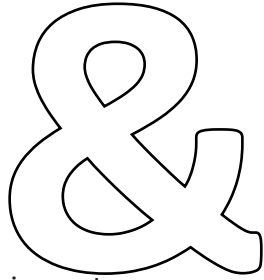

DONT'S

attempting to use the equipments.

1. Always read the instruction manual supplied along with the equipments and understand the correct installation and operating procedures before

trousers and jackets while operating potentially dangerous machines
2. It is important to use the personal protection equipments such as head helmet with visor, ear defenders, goggles, safety gloves, cut resistant shoes,
3. Avoid untrained persons using the equipments. Children must not be allowed to handle these equipments
4. Always use genuine spares and accessories in repairs and usage to derive maximum life of the equipments.
5. Always keep the equipments in good working condition to minimize loss of output as well as to reduce the pollution and save the environment
6. Do not use the machine within range of persons unless they wear protective clothing
7. Do not operate the machine when fatigued or under the influence of alcohol or drugs
8. For more query kindly contact for our Service Center/Dealer/ franchise

NO. 1 CHOICE OF FARMERS SINCE 1999



Marketed by.
**ratnagiri
impex**
BRINGING YOU THE FUTURE... NOW

RATNAGIRI IMPEX PVT., LTD.,

Annapurna House, #1 / 1G, 7th Cross, New
Guddadahalli

Mysore Road, Bangalore - 560 026

Missed Call : 7393 938 938

Email: ask@agrimart.in